	Printed, the document is not a controlled document.		Level:
	<b>095750-41A0 Duma Special</b>		Approved by: <b>CDH 2021.05.11</b>
	Document owner: <b>VriQM</b>	Version: <b>6.34</b>	Implementation: <b>2021.05.11</b>
Document users:	Document no.: <b>1.12.25.2</b>	Standard Product Database	

## Product Specification and Certificate

<b>Product no.</b>	095750-41A0
<b>Product name</b>	Duma Special 750 ml
<b>Product description</b>	100 mm round plastic container with a snap-on neck to be provided with Duma Handy Cap 9022. Index in the bottom. Intended for packaging of tablets and powder for Pharmaceutical use.
<b>Design</b>	<ul style="list-style-type: none"> <li>Regulatory drawing <a href="#">A095750 Regulatory</a></li> <li>Standard drawing <a href="#">B095750</a></li> </ul>
<b>Raw material</b>	Purell PE GF 4760, High-density polyethylene (HDPE) in compliance with Regulation (EU) 10/2011 and FDA title 21 CFR § 177.1520, LyondellBasell Industries. This product meets the standards set by the United States Pharmacopoeia USP 39 <661.1> Plastic Materials of Construction. Coloured with black masterbatch. <a href="#">Purell GF4760 Declaration</a>
<b>Colour</b>	18-2440-PBL-7 - Black, Polyethylene (PE) in compliance with Commission Regulation (EU) No 10/2011, Kunststoff-Kemi A/S <a href="#">18-2440-PBL-7 Declaration (supplier's productname PEFB3060)</a>
<b>Production</b>	<b>Facility:</b> Haarby, Denmark <b>Process:</b> The containers are injection blow moulded <b>Hygiene:</b> The production takes place in clean room <b>Sterilisation:</b> N/A

## Measures and Properties

<b>Dimensions:</b>			
Container:		Neck:	
Outside height	124.0 +2.0/-2.0 mm	Inside diameter	81.6 +0.3/-0.3 mm
Outside diameter	100.0 +1.0/-1.0 mm	Upper outside diameter	90.5 +0.3/-0.3 mm
		Neck ring diameter	94.2 +0.3/-0.3 mm
Wall thickness	Min. 0.4 mm		
<b>Other dimensions:</b>			
Label height	Max. 93 mm	Volume	Max. 878 ml
Label width	Max. 314 mm	Shelf life	5 years
Weight	44.5 +1.5/-1.5 gr	Bioburden	Max. 50 CFU

## Test Results

Moisture Vapour Transmission and Light Transmission tests are only carried out on products with white masterbatch.
Internal Reflectance and Differential Scanning Calorimetry tests are only carried out on products with white masterbatch.

	Printed, the document is not a controlled document.		Level:
	<b>095750-41A0 Duma Special</b>		Approved by: <b>CDH 2021.05.11</b>
	Document owner: <b>VriQM</b>	Version: <b>6.34</b>	Implementation: <b>2021.05.11</b>
Document users:	Document no.: <b>1.12.25.2</b>	Standard Product Database	

Physicochemical Tests set by the United States Pharmacopoeia USP <661.2> Plastic Packaging Systems for Pharmaceutical Use and Biological Reactivity Tests, In vitro set by the USP chapter <87> are only carried out on products with white masterbatch.

### Packing and Way of Delivery

The products are packed in 1 PE bag, which is then sealed. The PE bag is put into a cardboard carton, which is sealed with PP-tape. The cartons are packed on pallets, which are 1200 x 800 x 140 mm and weight approximately 23 kg.

#### Carton dimensions:

Height (mm): 645                      Length (mm): 830                      Width (mm): 415

#### Packing information:

Number of items per carton: 160                      Volume per carton (m<sup>3</sup>): 0.2142  
Max. number of cartons per pallet: 9                      Weight per carton (kg.): 8.7  
Max. height of the pallet (mm): 2300

### Labelling

Each carton is provided with a label with the following information:

- Manufacturer name
- Material name and number
- Batch / lot number and quantity
- Customer information (if requested)
- Country of origin
- Shelf life
- Production date and machine number

### Recommendation to Storage, Handling and Transportation

Stored inside in clean conditions in its original un-open packaging, protected from direct sunlight and with a temperature between 5 - 35° C and Relative Humidity between 30 - 70 %.

### Quality Control

All products are quality controlled according to instructions specified in our quality control system. We therefore guarantee that all deliveries from Primary Packaging Plastics have passed our control procedures and comply with the quality demands mentioned below. If required a certificate of conformance can be issued. The classification of defects and specifications of AQL values are based on ISO 2859 and Quality Assurance of Pharmaceutical and Cosmetic Packaging Materials:  
Defect Evaluation List for Blow-moulded Plastic Containers Vol. 23 - ISBN 3-87193-405-6.  
Defect Evaluation List for Injection-moulded parts made of Plastic: Closures, Sealing Disks and dosage aids (droppers, etc.) Vol. 22 - ISBN 3-87193-182-9.  
Documentation enclosed.  
[Quality Control - IBM Containers with special AQL values](#)

### Declaration of Conformity

[DoC EP \(GF 4760 Colored\)](#)  
[DoC Food Law- colored](#)  
[DoC TSE/BSE](#)  
[DoC Allergens, Phthalates, BPA, Latex, Melamine](#)  
[DoC TBA\\_TCA](#)

	Printed, the document is not a controlled document.	Level:
	<b>095750-41A0 Duma Special</b>	Approved by: <b>CDH 2021.05.11</b>
		Implementation: <b>2021.05.11</b>
Document owner: <b>VriQM</b>	Document no.: <b>1.12.25.2</b>	Standard Product Database
Version: <b>6.34</b>		
Document users:		

### Information on Packaging and Packaging Waste Directive 94/62/EC and/or CONEG

Both container, cap and bag are produced from material, which complies with the directions for plastics material in contact with foodstuffs. The content of heavy metals in the products, the inner bag, and the carton is less than 100 ppm.  
The packaging is recyclable for material recovery and/or well suited for energy recovery due to its high energy density. Reuse is technically possible depending on applicable regulations.

### REACH

We can confirm that the raw materials used in the product are either pre-registered or exempted from pre-registration.

### Complaint Handling

In case that the delivered products are outside specification, complaint must be send in writing to daily contact person in Customer Care Center.

In order to ensure a thorough investigation it is important to send the following basic information:

- Article number
- Batch number
- Cavity number (if related to specific cavities)
- Number of defective items
- Defect observed in
  - a) incoming control including sample size
  - b) production including quantity of items used
  - c) final products including quantity of items used
  - d) market complaint
- Defect found in
  - a) one carton
  - b) several cartons - please specify quantity
- Exact production date/time from carton/bag or carton/bag/pallet number products in quarantine:
  - a) Filled products - Quantity
  - b) Not filled products - Quantity
  - c) No products left
- Description of the defect

The following standard form can be used: 3.1 Customer Complaint Report.

Depending on the defect, additional information will be requested as described in the attached standard forms: 2.5 Information requested in relation to complaints.

It is very important to send samples at the time a complaint is filed, as any delay in these can have an impact on time of investigation. An investigation report is send to Customer within 21 days counting from when complaint, relevant information and samples are received.

#### Important !

Filled or empty products involved in a complaint to Primary Packaging Plastics, must only be destroyed by Customer after written approval from Gerresheimer.

	Printed, the document is not a controlled document.		Level:
	<b>095750-41A0 Duma Special</b>		Approved by: <b>CDH 2021.05.11</b>
	Document owner: <b>VriQM</b>	Version: <b>6.34</b>	Implementation: <b>2021.05.11</b>
Document users:	Document no.: <b>1.12.25.2</b>	Standard Product Database	

Any activity in connection with a complaint where Customer expect Gerresheimer to cover the costs must be approved by Gerresheimer in writing before initiation of the activity.

[Complaint report](#)

[Labelling](#)

[Loose silica gel-loose desiccant-defect on desiccant](#)

[Mix-up](#)

[Partly- or disconnected TE-rings](#)

[Product defect](#)

[Transport](#)

## Registrations and Certifications

**Primary Packaging Plastics was established in 2020. Before that time the company was working under the following names: Gerresheimer Plastic Packaging, Superfos Pharma, Superfos Pharma Pack, Dudek Plast and Duma.**

Documentation, i.e. test reports, certificates etc. issued before July 2020 will be with reference to one of the names above.

**Gerresheimer Vaerloese A/S has obtained the following registrations and certifications for Vaerloese and Haarby, Denmark:**

ISO 9001, no. 160454-2014-AQ-DEN-DANAK

ISO 14001, no. 156579-2014-AE-DEN-DANAK

ISO 15378, no. 160455-2014-Q-DEN-DNV

ISO 45001, no. 10000341648-MSD-DANAK-DNK

**The product is FDA registered in US with the following DMF number:**

DMF 12077 - DMF type III Packaging material, Manufactured in Vaerloese - Denmark, Haarby - Denmark.

**The product is TPD registered in Canada with the following DMF number:**

DMF 2000-108 - Packaging material – Drug Master File. Packaging material, Manufactured in Vaerloese - Denmark, Haarby - Denmark.

**China registration for appropriate products - pending.**

**The product is registered in Russia with the following number:**

C3 2011/11203 – plastic packages in size between 3ml to 3000 ml with accessories.

## Revisions

Version:	Implementation:	Revision information:
<a href="#">1</a>	2010.02.08	Transfer to new system, additional information and change in dimensions/tolerances of inside diameter, upper outside diameter and neck ring diameter
<a href="#">2.1</a>	2010.03.16	Change in dimension of inside diameter and recorection of version number from 1.0 to 2.1
<a href="#">2.2</a>	2010.06.08	Change of Quality control

	Printed, the document is not a controlled document.		Level:
	<b>095750-41A0 Duma Special</b>		Approved by: <b>CDH 2021.05.11</b>
	Document owner: <b>VriQM</b>	Version: <b>6.34</b>	Implementation: <b>2021.05.11</b>
Document users:	Document no.: <b>1.12.25.2</b>	Standard Product Database	

<a href="#">2.3</a>	2010.12.05	GF 4760 Declaration 2010: Updated declaration
<a href="#">2.4</a>	2011.07.13	GF 4760 Declaration 2011: Updated GF4760 declaration GF 4760 - Black: Updated Regulation (EU) 10/2011
<a href="#">2.5</a>	2012.01.31	Registrations and Certifications: More precise description of registrations
<a href="#">2.6</a>	2012.03.15	GF 4760 Declaration 2012: Updated
<a href="#">2.7</a>	2012.05.29	Hrb IBM containers: Production takes place in clean room
<a href="#">2.8</a>	2012.08.09	Purell PE GF 4760 declaration 2012: Updated
<a href="#">2.9</a>	2013.04.08	Purell GF4760 Declaration 2013: Updated
<a href="#">3</a>	2013.08.30	Packed in 1 LDPE bag instead of 2. Weight per carton changed from 7.7 to 8.7 kg.
<a href="#">3.1</a>	2013.12.05	Purell GF4760 Declaration 2013: Updated
<a href="#">3.2</a>	2014.01.13	18-2440-PBL-7 Declaration 2013 (supplier's productname PEFB3060): Updated
<a href="#">3.3</a>	2014.02.25	Purell GF4760 Declaration 2014: Updated
<a href="#">3.4</a>	2014.07.08	18-2440-PBL-7 Declaration (supplier's productname PEFB3060): Updated with Regulation 202/2014
<a href="#">3.5</a>	2014.07.09	Purell GF4760 Declaration 2014: Updated
<a href="#">3.6</a>	2015.03.23	Purell GF4760 Declaration 2015: Updated
<a href="#">3.7</a>	2016.01.11	Purell GF4760 Declaration 2016: New SVHC list - 17.12.2015
<a href="#">3.8</a>	2016.05.10	Registrations and Certifications: Updated
<a href="#">4</a>	2016.06.29	Regulatory drawing, Declaration of Conformity and Complaint handling added
<a href="#">4.1</a>	2016.06.29	Quality Control - General text: New classification of defects Quality Control - IBM Containers with special AQL values: Updated
<a href="#">4.2</a>	2016.08.03	Purell GF4760 Declaration 2016: New SVHC list 20.06.2016
<a href="#">4.3</a>	2016.08.12	Kunststof-Kemi 18-2440-PBL-7: Regulation 10/2011
<a href="#">5</a>	2016.09.14	Information regarding USP tests updated
<a href="#">5.1</a>	2016.09.28	Purell GF4760 Declaration 2016: Updated with 1416/2016
<a href="#">5.2</a>	2016.11.10	Physico/In vitro - Not white: Wording changed
<a href="#">5.3</a>	2016.12.08	18-2440-PBL-7 Declaration (supplier's productname PEFB3060): Updated
<a href="#">5.4</a>	2017.01.19	Purell GF4760 Declaration 2017: Updated SVHC list - 12.01.2017
<a href="#">5.5</a>	2017.04.03	Caps VRL: Packed in PE bag
<a href="#">5.6</a>	2017.05.18	Purell GF4760 Declaration 2017: Updated with 2017/752
<a href="#">5.7</a>	2017.09.28	Purell GF4760 Declaration 2017: Updated with USP chapter <661.1> GF 4760 - Black: Updated with USP chapter 661.1
<a href="#">5.8</a>	2017.10.26	DoC TSE/BSE: Updated (yearly update)
<a href="#">5.9</a>	2017.11.28	DoC Allergens, Phthalates, BPA, Latex, Melamine: Yearly update
<a href="#">5.10</a>	2017.12.21	Quality Control - IBM Containers with special AQL values: Updated
<a href="#">5.11</a>	2018.02.12	Purell GF4760 Declaration: New SVHC list 15.01.2018
<a href="#">5.12</a>	2018.04.03	18-2440-PBL-7 Declaration (supplier's productname PEFB3060): Updated with 79/2018
<a href="#">5.13</a>	2018.05.14	Purell GF4760 Declaration: Updated

	Printed, the document is not a controlled document.		Level:
	<b>095750-41A0 Duma Special</b>		Approved by: <b>CDH 2021.05.11</b>
	Document owner: <b>VriQM</b>	Version: <b>6.34</b>	Implementation: <b>2021.05.11</b>
Document users:	Document no.: <b>1.12.25.2</b>	Standard Product Database	

5.14	2018.07.30	Purell GF4760 Declaration: Updated SVHC list 27.06.2018
5.15	2018.09.18	Purell GF4760 Declaration: Updated due to regulation 2016/1416
6	2018.09.24	DoC TBA TCA added
6.1	2018.11.20	GF 4760 - Black: Unified description
6.2	2019.01.21	Purell GF4760 Declaration: Updated SVHC list 15.01.2019
6.3	2019.02.21	Registrations and Certifications with FDA,TPD, Russia and China: Updated - China registration.
6.4	2019.03.25	DoC TSE/BSE: Yearly update DoC Allergens, Phthalates, BPA, Latex, Melamine: Yearly update
6.5	2019.03.28	DoC EP (GF 4760 Colored): Yearly update
6.6	2019.04.30	IR/DSC - Not white: Text updated
6.7	2019.07.31	Purell GF4760 Declaration: Updated SVHC list_ 16.07.2019
6.8	2019.09.03	Labelling: Updated
6.9	2019.09.17	Purell GF4760 Declaration: Updated with 2019/1338
6.10	2020.01.28	DoC Food Law- colored: Updated with MG Container colored
6.11	2020.03.17	Purell GF4760 Declaration: Updated SVHC List_ 16.01.2020
6.12	2020.03.24	DoC TSE/BSE: Yearly updated
6.13	2020.04.06	DoC EP (GF 4760 Colored): Yearly update.
6.14	2020.04.14	DoC TSE/BSE: Updated name to Primary Packaging Plastics DoC Allergens, Phthalates, BPA, Latex, Melamine: Updated name to Primary Packaging Plastics
6.15	2020.04.15	Registrations and Certifications with FDA,TPD, Russia and China: Updated name to Primary Packaging Plastics
6.16	2020.04.16	DoC TBA_TCA: Updated
6.17	2020.04.20	DoC EP (GF 4760 Colored): New division name_Primary Packaging Plastic
6.18	2020.04.29	Complaint handling: New division name_Primary Packaging Plastic
6.19	2020.07.01	Purell GF4760 Declaration: Updated SVHC List_ 25.06.2020
6.20	2020.08.18	Registrations and Certifications with FDA,TPD, Russia and China: ISO 45001 obtained
6.21	2020.08.19	Physico/In vitro - Not white: Wording changed
6.22	2020.08.25	Quality Control - General text: Updated name Primary Packaging Plastics
6.23	2020.09.17	18-2440-PBL-7 Declaration (supplier's productname PEFB3060): Updated SVHC List_ 25.06.2020
6.24	2021.01.26	Purell GF4760 Declaration: Updated SVHC List 19.01.2021 18-2440-PBL-7 Declaration (supplier's productname PEFB3060): Updated SVHC list 19.01.2021
6.25	2021.03.03	Quality Control - IBM Containers with special AQL values: Updated with Primary Packaging Plastics
6.26	2021.04.15	DoC EP (GF 4760 Colored): Yearly update and change of company logo
6.27	2021.04.16	DoC Food Law- colored: Yearly update and change of company logo
6.28	2021.04.22	Labelling Loose silica gel-loose desiccant-defect on desiccant
6.29	2021.04.23	

	Printed, the document is not a controlled document.		Level:
	<b>095750-41A0 Duma Special</b>		Approved by: <b>CDH 2021.05.11</b>
			Implementation: <b>2021.05.11</b>
Document owner: <b>VriQM</b>	Document users:		Document no.: <b>1.12.25.2</b>
Version: <b>6.34</b>			Standard Product Database

		Packing and Packing waste directive: Updated. Partly- or disconnected TE-rings Product defect Transport
6.30	2021.04.27	Complaint report DoC TSE/BSE: Change of company logo
6.31	2021.05.04	Mix-up
6.32	2021.05.07	Labelling
6.33	2021.05.10	Loose silica gel-loose desiccant-defect on desiccant Mix-up Partly- or disconnected TE-rings Product defect Transport
6.34	2021.05.11	Complaint report

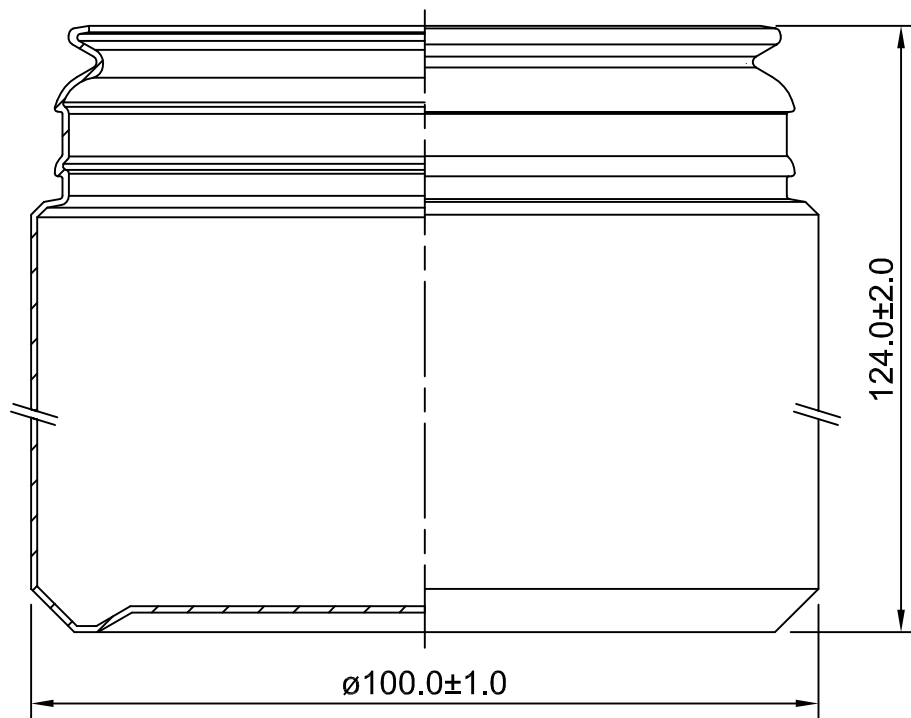

Round 750ml					
Replaced drawing					Gerresheimer Vaerloese A/S      Phone +45 4477 7888 Walgerholm 2-8, Postbox 229      Fax. +45 4477 7892 DK-3500 Vaerloese
Designer	Hek	09.01.2015	This drawing may not be handed over, copied or used by others		
Released	BS	09.01.2015	Item	No.	
Scale	Drawing Type	Size	Duma special 095750	A095750	
1 : 1	Regulatory	A4			Vers. no.: 1

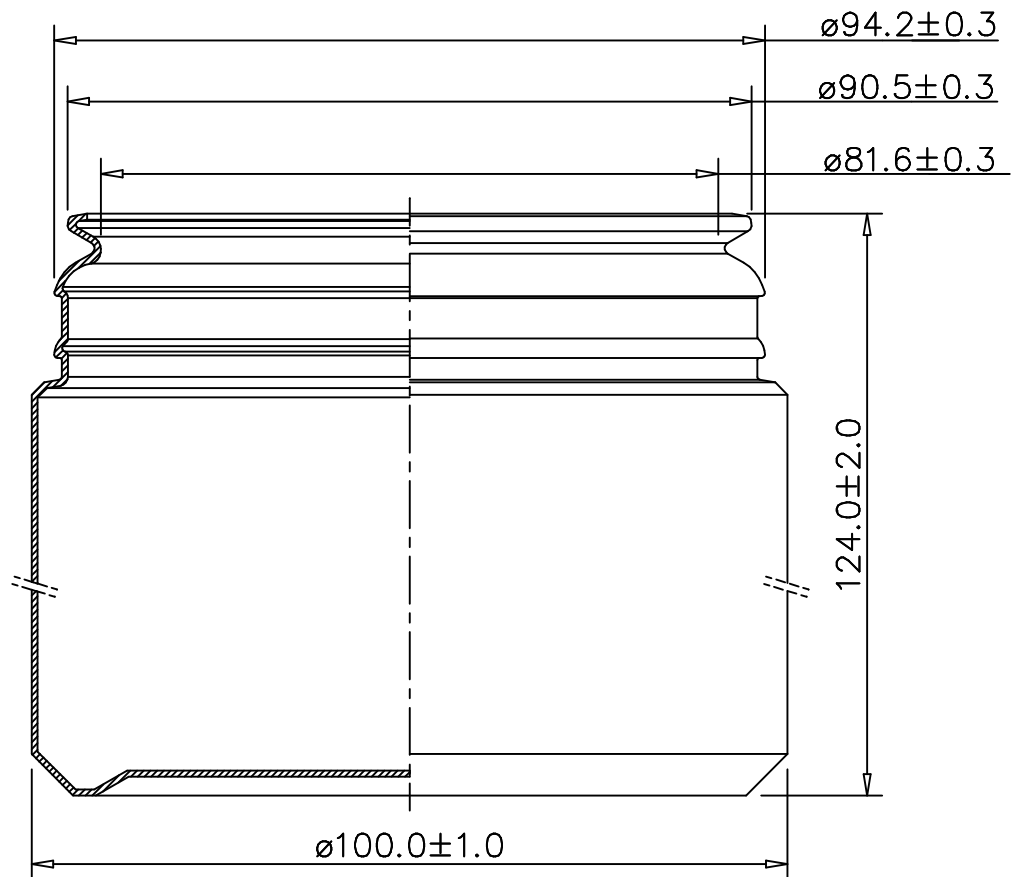
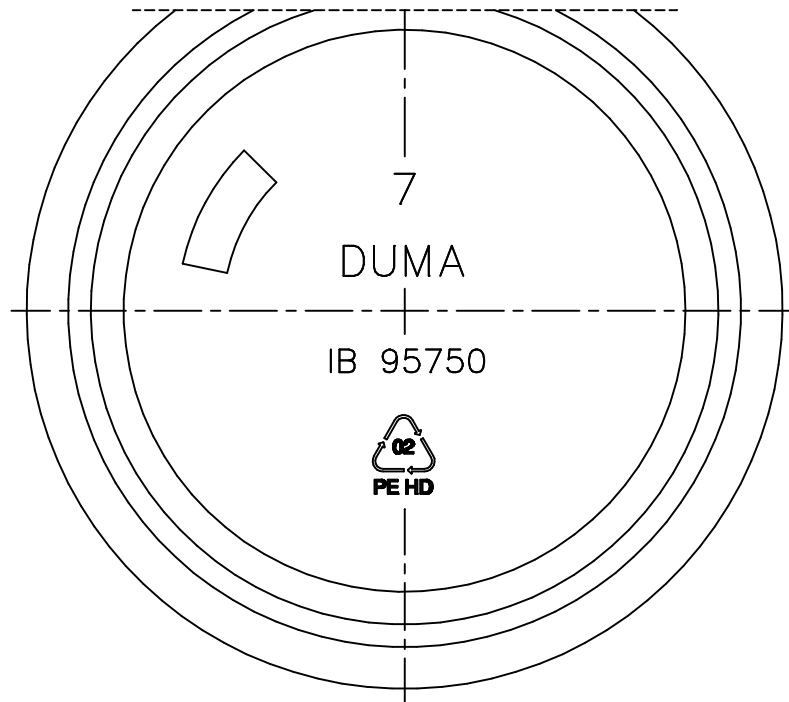

Tolerance changed	03.03.2010	MG	03.03.2010	
Tolerance changed	29.12.2009	MG	29.12.2009	
Tolerance changed	25.09.2009	MG	25.09.2009	
Recycle mark added	20.04.2009	JJ	20.04.2009	
Logo changed	20.04.2009	JJ	20.04.2009	
No. and logo changed	17.03.2006	JJ	17.03.2006	
Drawing nr. reduced	12.2005	JJ	12.2005	
Dimension erased	08.2005	JJ	08.2005	
Dimension added	07.2004	JJ	07.2004	
Created	05.2000	JJ	05.2000	
Created / Correction	Date	Sign.	Appr. Date	Sign.

## GERRESHEIMER

Gerresheimer Vaerloese A/S  
Walgerholm 2-8, Postbox 229  
DK-3500 Vaerloese

Phone +45 4477 7888  
Fax. +45 4477 7892

This drawing may not be handed over, copied or used by others

Item  
Duma Special  
095750 750ml.

No.  
B095750  
Vers. no.: 1

January 26, 2021

Katarzyna Jawor  
Gerresheimer Boleslawiec S.A.  
Gerresheimer Boleslawiec S.A.  
Boleslawa Chrobrego 15  
59 700 Boleslawiec



***Purell PE GF4760***

A product of Basell Sales & Marketing Company B.V.; Delftseplein 27E 3013 AA; Rotterdam, Netherlands

Dear Katarzyna Jawor:

The following is in response to your request for Product Stewardship Information (PSInfo) for the product listed above. The attached Product Stewardship Bulletin (PSB) details the regulatory status of this product.

LyondellBasell Industries responds to product stewardship requests with a standardized Product Stewardship Bulletin (PSB) which summarizes the global regulatory status of a product. LyondellBasell Industries will not complete customers' forms or questionnaires. Standardized responses provide each customer with consistent information in a timely fashion. Each request is reviewed to ensure our response documents provide relevant information.

Please note that compliance with these regulations should not be interpreted to guarantee that the product, will, in fact, perform in a particular application. Your Technical Service Representative can help you determine that the characteristics of the product are compatible with the desired conditions of use.

Should you have any further questions concerning a LyondellBasell product, or if we can assist in any other way, please do not hesitate to contact us.

Best regards,

A handwritten signature in grey ink, appearing to read 'M. Poltronieri'.

Micaela Poltronieri  
Product Safety Specialist  
+39 0532 46 8087  
micaela.poltronieri@lyondellbasell.com

# Product Stewardship Bulletin



## ***Purell* PE GF4760**

A product of Basell Sales & Marketing Company B.V.; Delftseplein 27E 3013 AA; Rotterdam, Netherlands

### **Global Food Contact Status:**

#### **European Union**

This product complies with the relevant requirements of Regulation 1935/2004/EC (Framework Regulation) as applicable to intermediate materials (e.g. plastic powders, plastic granules or plastic flakes).

This product complies with the relevant requirements of Regulation 2023/2006/EC (GMP) and as amended, applicable to intermediate materials (e.g. plastic powders, plastic granules or plastic flakes).

This product complies with the relevant requirements of Regulation 10/2011/EC (PIM) as amended, applicable to intermediate materials (e.g. plastic powders, plastic granules or plastic flakes).

The monomers and additives used to produce this product are listed in the Union List of Authorized Substances of Regulation 10/2011/EC and subsequent amendments.

EU Regulation 10/2011/EC specifies 10 mg/dm<sup>2</sup> as the maximum overall migration (OML) from the finished plastic food contact material or article. The OML and SMLs (when applicable) should be determined according to the requirements specified in EU Regulation 10/2011/EC and subsequent amendments. The OML and SML determinations are the responsibility of the manufacturer of the finished plastic food contact material or article. In addition, we remind you that the manufacturers of the finished food contact material or article must verify that the finished material or article, manufactured according to good manufacturing practices, does not modify the organoleptic properties of the food.

#### SML Components

This product contains one or more components with Specific Migration Limits (SMLs).

93280; distearylthiodipropionate; SML(T) = 5 mg/kg (14).

68320; Octadecyl 3(3,5-Di-tert-butyl-4-hydroxyphenyl) propionate; SML = 6 mg/kg

This product contains traces of a substance which is regulated with a specific migration limit in EU (Commission Regulation 10/2011; Annex II). Migration tests showed a migration level significantly below the SML, thus exceeding this SML under foreseeable conditions of use involving food contact is not expected.

SML = 1 mg/kg (expressed as Aluminium)

This product contains one or more Dual Use Additives as defined in Regulation 10/2011/EC.

- ▶ E 470a Calcium salts of fatty acids

### **United States**

The base resin in this product meets the FDA requirements contained in the Code of Federal Regulations in 21 CFR 177.1520(a)(3)(i) and (c)3.2a.

This product may also contain adjuvant substances that may be safely used in polymers used for the manufacture of articles that come into direct contact with food. According to our information, the substances used in this product meet the requirements of their respective FDA regulations and 21 CFR 177.1520(b).

This product meets the FDA criteria in 21 CFR 177.1520 for food contact applications, including cooking, listed under conditions of use A through H in 21 CFR 176.170(c), Table 2, and can be used in contact with all food types as listed in 21 CFR 176.170(c), Table 1.

### **Japan**

Food Contact Positive Lists by Japan's Ministry of Health, Labour and Welfare (MHLW) issued on April 28th, 2020 and effective on June 1st, 2020

The base resin of this product is listed in the Positive List of Base Polymers.

The additive(s) used in this product is/are listed in the Positive List of Additives authorized for use in the Base Resin of this product.

### **Allergen Statements**

#### **Allergen - Food Allergen European Regulation 1169/2011**

The food ingredients listed in Annex II of Regulation (EU) No 1169/2011, are not used in the manufacture of or formulation of this product. However, this product has not been tested for these substances.

### **Biomedical Policy**

This product(s) may not be used in:

(1) U.S. FDA Class III, Health Canada Class IV, and/or European Class III Medical Devices; or (2) applications involving permanent implantation into the body.

Prior written approval for each specific product and application must be given by LyondellBasell before this product(s) is used in any:

(1) U.S. FDA Class I, Health Canada Class I, and/or European Union Class I Medical Devices; (2) U.S. FDA Class II, Health Canada Class II or Class III, and/or European Union Class II Medical Devices; (3) film, overwrap and/or product packaging that is considered a part or component of one of the aforementioned Medical Devices; or (4) packaging in direct contact with a pharmaceutical active ingredient and/or dosage form that is intended for inhalation, injection, intravenous, nasal, ophthalmic (eye), digestive, or topical (skin) administration

All references to U.S. FDA, Health Canada, and European Union regulations include other country's equivalent regulatory classifications.

LyondellBasell may further prohibit or restrict the sale of its products into certain applications. For further information, please contact a LyondellBasell representative or visit the LyondellBasell website at:

<https://www.lyondellbasell.com/en/products-technology/product-safety-stewardship/>

### **Animal Based Raw-Materials (BSE/TSE)**

#### **Tallow**

Tallow derived additives may be used in the manufacture of this product.

#### **Europe - BSE/TSE - "Mad Cow"**

Tallow derived materials used in this product fulfill the requirements laid down in the Regulations 1069/2009/EC, and 142/2011/EC, and the "Note for Guidance EMA/410/01, and as amended.

#### **Epoxy Derivatives**

The materials BADGE, BFDGE or NOGE are not intentionally added in this product as referenced in Commission Regulation 1895/2005/EC, on the use of certain epoxy derivatives in materials and articles intended to come into contact with foodstuffs as plasticizers, additives or raw materials.

#### **California Prop 65**

Please refer to the US SDS for communications regarding California Proposition 65. In case the US SDS is not available, please contact [global.chem.control@lyondellbasell.com](mailto:global.chem.control@lyondellbasell.com).

#### **Conflict Minerals (Dodd-Frank Wall Street Reform and Consumer Protection Act - September, 2010)**

Please see link below for the position of LyondellBasell concerning this Act:

<https://www.lyondellbasell.com/en/investors/corporate-governance/?id=52>

The link to this document is located in the right margin under the heading "Corporate Governance Documents" titled "Conflict Minerals Policy".

### **Genetically Modified Organisms (GMO)**

Additives derived from Genetically Modified Organisms (GMO's) are not intentionally used in the formulation of this product.

### **Halal Certification**

This product is not certified as Halal.

### **Kosher Certification**

This product is not certified Kosher.

### **Latex**

No materials containing latex or natural rubber are used in the manufacturing, handling and packaging processes for this product.

### **Medical**

#### **European Pharmacopeia (EP)**

This product meets the requirements of the monographs 3.1.3 ( Polyolefins ) and 3.1.5 (Polyethylene with additives for containers for parenteral preparations and for ophthalmic preparations) - European Pharmacopoeia Edition 10.

#### **ISO 10993**

Biological reactivity evaluations have been performed on representative samples of this product according with the requirements of USP 661.1; specifically the Chapter 88 - USP Biological Reactivity Tests, In Vivo for a Class VI plastic (Systemic Injection Test, Intracutaneous Test, Implantation Test) and Chapter 87 - Biological Reactivity Tests, in Vitro for polymeric materials (Elution Test). These USP tests may fit the requirements of certain sections of ISO 10993-5 (tests for in vitro cytotoxicity), 10993-10 (tests for irritation and skin sensitization) and 10993-11 (tests for systemic toxicity). Despite this, the manufacturer of a medical device made with this product must still evaluate the medical device to show that it fully meets the requirements of the applicable sections of ISO 10993.

#### **US Pharmacopeia (USP)**

Representative samples of this product meet the requirements of USP Chapter 661.1 (Edition USP 39).

## US FDA Drug Master File (DMF)

Information on this product is listed in DMF N. 5654. Contact LyondellBasell for a DMF authorization letter to be sent to FDA.

## ICH Harmonized Guideline Q3D (Elemental Impurities)

The elemental impurities of Class 1, 2, 3 listed in the ICH Harmonized Guideline Q3D of 22 March 2019 are not intentionally used in the manufacture or formulation of this product. However this product has not been tested for these substances.

## Metals Content

## US CONEG

Based on the available documentation provided by our raw material suppliers, this product complies with the CONEG Model Legislation for requirements regarding the defined limit for the sum of heavy metals (lead, mercury, cadmium and hexavalent chromium).

## EU Packaging and Packaging Waste

Based on the available documentation from raw materials suppliers, this product complies with the directive 94/62/EC and as amended concerning the defined limit(s) of heavy metals.

## Restriction of Hazardous Substances in Electric and Electronic Equipment (RoHS)

RoHS Regulation refers to electrical and electronic equipment and not specifically to plastic raw materials. However, based on the available documentation from raw materials suppliers, this product complies with the requirements of the Directives 2002/95/EC and 2011/65/EU, as amended, concerning the limits of cadmium, lead, mercury, hexavalent chromium, polybrominated biphenyls (PBB), polybrominated diphenyl ethers (PBDE), bis(2-ethylhexyl)phthalate (DEHP), butyl benzyl phthalate (BBP), Dibutyl phthalate (DBP) and diisobutyl phthalate (DIBP).

## Nanomaterials

Nanomaterials (defined as natural, incidental or manufactured materials containing particles, in an unbound state or as an aggregate or as an agglomerate and where, for 50 % or more of the particles in the number size distribution, one or more external dimensions is in the size range 1 nm - 100 nm) are not used in the manufacture of or the formulation of this grade. However, this product has not been tested for these chemical substances.

## Other Chemicals

The chemical materials listed below are not intentionally used in the manufacture or the formulation of this product. However, this product has not been tested for these chemical materials.

- ▶ 2-(2H-1, 2, 3-Benzotriazol-2-yl)-4,6-di-tert-butylphenol; (Benzotriazole); CAS# 3846-71-7;
- ▶ 2,4,4'-trichloro-2'-hydroxydiphenyl ether; (Triclosan); CAS# 3380-34-5;

- ▶ 2-mercaptobenzothiazole; MBT; CAS# 149-30-4;
- ▶ Acrolein; (propenal); (CAS# 107-02-8);
- ▶ Acrylamide; CAS# 79-06-1;
- ▶ Aromatic amines;
- ▶ Asbestos;
- ▶ Azo Dyes and Pigments;
- ▶ Polyaromatic Hydrocarbons - PAHs:
  - 1,2-dihydro-acenaphthene; (CAS# 83-32-9);
  - 9H-Fluorene; (CAS# 86-73-7);
  - Acenaphthylene; (CAS# 208-96-8);
  - Anthracene; (CAS# 120-12-7);
  - Benz(a)anthracene; (CAS# 56-55-3);
  - Benzo(a)pyrene; (CAS# 50-32-8);
  - Benzo(b)fluoranthene; (CAS# 205-99-2);
  - Benzo(e)pyrene; (CAS# 192-97-2);
  - Benzo(ghi)perylene; (CAS# 191-24-2);
  - Benzo(j)fluoranthene; (CAS# 205-82-3);
  - Benzo(k)fluoranthene; (CAS# 207-08-9);
  - Chrysene; (CAS# 218-01-9);
  - Dibenz(a,h)anthracene; (CAS# 53-70-3);
  - Fluoranthene; (CAS# 206-44-0);
  - Indeno(1,2,3-cd)pyrene; (CAS# 193-39-5);
  - Naphthalene; (CAS# 91-20-3);
  - Phenanthrene; (CAS# 85-01-8);
  - Pyrene; (CAS# 129-00-0);
- ▶ Benzophenone; CAS RN 119-61-9;
- ▶ Bisphenol A; (BPA); CAS# 80-05-7;
- ▶ Bisphenol A diglycidyl ether; (BADGE); CAS# 1675-54-3;
- ▶ Bisphenol F diglycidyl ether; BFDGE; CAS# 2095-03-6;
- ▶ Butylated hydroxyanisole; (BHA); CAS# 121-00-6 & 25013-16-5;
- ▶ Butylated hydroxytoluene; (BHT); CAS# 128-37-0
- ▶ Chlorinated paraffins;
- ▶ Cyanuric acid; (Isocyanuric Acid or CYA); CAS# 108-80-5;
- ▶ Dimethyl fumarate; (DMF); CAS# 624-49-7;
- ▶ Dioxins;
- ▶ Epichlorohydrin; (ECH); CAS# 106-89-8;
- ▶ Fluorocarbons;
- ▶ Fluorotelomers
- ▶ Formaldehyde; CAS# 50-00-0;

- ▶ Formaldehyde in specific conditions could be formed during further resin processing (see SDS)
- ▶ Gold(Au); CAS# 7440-57-5;
- ▶ Halogenated Flame Retardants
- ▶ Melamine; (1,3,5-Triazine-2,4,6-triamine); CAS# 108-78-1;
- ▶ Nitrosamines;
- ▶ Nonylphenol; CAS# 25154-52-3;
- ▶ Nonylphenol ethoxylates;
- ▶ Novolac glycidyl ether;
- ▶ Organotin compounds;
- ▶ Perfluorochemicals; (PFCs);
- ▶ Perfluorooctane sulfonate; (PFOS); CAS# 1763-23-1;
- ▶ Perfluorooctanoic acid; (PFOA); CAS# 335-67-1;

Plasticizers (e.g. DEHA, DINCH, BTHC, TOTM, etc.):

DEHA bis(2-ethylhexyl) adipate; CASRN: 103-23-1

DINCH 1,2-Cyclohexanedicarboxylic acid, 1,2-diisononyl ester, CASRN: 166412-78-8

BTHC butyryl tri-n-hexyl citrate; CASRN: 82469-79-2;

TOTM tris(2-ethylhexyl)benzene-1,2,4-tricarboxylate; CASRN: 3319-31-1

DINP; Diisononyl Phthalate; CASRN: 28553-12-0;

DEHP; di(2-ethylhexyl) phthalate

DOP; di-octyl phthalate; CASRN: 117-81-7;

DIDP; di-iso-decyl phthalate; CASRN: 26761-40-0;

DBP; di-butyl phthalate; or DNBP; di-n-butyl phthalate; CASRN 84-74-2;

BBP; butyl benzyl phthalate; CASRN 85-68-7;

DNOP; di-n-octyl phthalate; CASRN: 117-84-0;

Glycerides, castor-oil mono-, hydrogenated, acetates; CASRN: 736150-63-3

- ▶ Polybrominated biphenyls; (PBBs);
- ▶ Polybrominated diphenyl ethers; (PBDEs);
- ▶ Polybrominated terphenyls; (PBTs);
- ▶ Polychlorinated biphenyls; (PCBs);
- ▶ Polychlorinated naphthalenes; (PCNs);
- ▶ Polychlorinated terphenyls; (PCTs);
- ▶ Polystyrene;
- ▶ Polyvinyl chloride; (PVC); CAS# 9002-86-2;
- ▶ Radioactive substances;
- ▶ Radon; CAS# 10043-92-2;
- ▶ Styrene monomer; CAS# 100-42-5;
- ▶ Sulphur dioxide; CAS# 7446-09-5;

- ▶ Tin oxide (SnO<sub>2</sub>); (Cassiterite); CAS# 8062-08-6;
- ▶ Tris-nonylphenol phosphite; (TNPP); CAS# 26523-78-4;
- ▶ Vinyl chloride monomer; CAS RN 75-01-4; VCM
- ▶ Wolframite; Tungsten (W); CAS# 1332-08-7;

## Ozone Depleting Substances

### European Union

The ozone-depleting substances (ODS), listed in the Annexes I & II of the Regulation ( EC ) No 1005/2009 of 16 September 2009, are not intentionally used in the manufacture of or formulation of this product.

### United States

Materials listed in the Clean Air Act Amendments of 1990 (Class I, CFCs and Class II, HCFC's, Halons and the solvents, carbon tetrachloride and 1,1,1-trichloroethane) are not intentionally used in the production of this product.

### Phthalates

Phthalates are not used in the manufacture of or the formulation of this product. However, this product has not been tested for phthalates.

### REACH Substances of Very High Concern (SVHC)

This product does not contain any of the Annex XIV substances on the Authorisation list or Annex XIV candidate chemicals proposed to be Substances of Very High Concern for Authorisation (List as of January 19, 2021) above the 0.1 % threshold as stated in REACH (Article 57, Regulation No. 1907/2006) determined either through (i) non-use of the substance, (ii) mass balance calculation, or (iii) specific testing. The current list of all SVHCs can be found at ECHA website link listed below:

<https://www.echa.europa.eu/candidate-list-table>

### Global Chemical Control Regulations

All ingredients in this product are in compliance with the following chemical inventories:

See Section 15, of the SDS (Safety Data Sheet) for Global Chemical Inventories.

### Global Toy Regulations

CEN EN Standards refer to safety of toys and not specifically to plastic raw materials. According to the information provided by our raw material suppliers, we deem this product should comply with the requirements of CEN standards EN71-3 / EN71-9 (as amended) as applicable to plastic raw materials (pellets, powder, flakes). However, this product has not been tested according to these CEN Standards.

## **VOC Content**

### **Switzerland VOC Declaration**

This product contains less than 3% VOC's of the substances in the positive lists of the Switzerland Regulations "VOC-LENKUNGSABGABE."

### **CEN Standard EN 13432:2004**

This product is not suitable for composting.

### **Energy Recovery - CEN Standard EN 13431:2004**

The calorific gain from polyethylene in an energy recovery process is 22 MJ/Kg.

### **Disclaimer on Pass/Fail Status**

Compliance statements, or statements regarding pass/fail status provided by Seller in this document are based on testing of representative samples and/or product composition assessment.

Seller makes no express or implied warranty by virtue of disclosing compliance or pass/fail status.

### **Disclaimer**

Information in this document is accurate to the best of our knowledge at the date of publication. The document is designed to provide users general information for safe handling, use, processing, storage, transportation, disposal and release and does not constitute any warranty or quality specification, either express or implied, including any warranty of merchantability or fitness for any particular purpose. Users shall determine whether the product is suitable for their use and can be used safely and legally.

In addition to any prohibitions of use specifically noted in this document, LyondellBasell may further prohibit or restrict the sale of its products into certain applications. For further information, please contact a LyondellBasell representative.

### **Trademarks**

The Trademark referenced within the product name is owned or used by the LyondellBasell family of companies.

Gerresheimer Vaerloese A/S · Walgerholm 2-8 · DK-3500 Vaerloese · Denmark

## Plastic Packaging

Gerresheimer Vaerloese A/S  
Walgerholm 2-8  
3500 Vaerloese  
Denmark

Managing Director:  
Niels Düring

Registered Seat: Vaerloese  
VAT No. 10417430

e-mail      katarzyna.jawor@gerresheimer.com  
Internet     www.gerresheimer.com

September 16, 2020

Based upon information from supplier of masterbatch, Gerresheimer Vaerloese A/S hereby confirms that 18-2440-PBL-7 has supplier product name PEFB3060.

Yours sincerely,



Katarzyna Jawor

Compliance Specialist

Primary Packaging Plastics



Hubron (International) Limited

Albion Street,  
Failsworth, Manchester,  
M35 0FP, England

Tel: +44(0)161 681 2691  
Fax: +44(0)161 683 4658  
E-mail: [sales@hubron.com](mailto:sales@hubron.com)  
Web: [www.hubron.com](http://www.hubron.com)

## Product Compliance

### Black Masterbatch PEFB 3060

#### European Union:

**Framework regulation (EC) 1935/2004 and European Commission Regulation (EU) No 10/2011 of 14<sup>th</sup> January 2011 on plastic materials and articles intended to come into contact with food:**

The composition of PEFB 3060 complies with the relevant requirements of the above framework and commission regulation when dosed at a **maximum 6.25% w/w**.

The monomers/ additives used in the formulation are listed in the positive list (Annex I; Table 1 or 2 of [EU]10/2011) with the following migration restrictions: **None**

The following Dual Use Additives are present in PEFB 3060: E471

Other additives associated with the masterbatch polymer carrier.  
Dual use additives = **None**

The above statement remains unaffected by Commission Regulation (EU) No 321/2011, (EU) No 1282/2011, (EU) No 1183/2012, (EU) No 202/2014 (EU) No 174/2015, (EU) No 1416/2016, (EU) No752/2017, (EU) No79/2018, (EU) No 213/2018, (EU) No 2019/37, (EU) No 988/2019, (EU) 2019/1338 and (EU) 2020/1245.

Black masterbatch PEFB 3060 is manufactured using good manufacturing practices as specified by Regulation (EC) No 2023/2006.

The above mentioned masterbatch is manufactured using a carbon black material which is in accordance with **European Resolution AP (89) 1** 'on the use of colourants in plastic materials coming into contact with food'

#### **REACH Regulation (EC) 1907/2006 & Commission Regulation (EU) No 1272/2013**

Raw materials and processes used in the manufacture of PEFB 3060 none are listed on the SVHC List issued 19/01/2020 (211 Items).

No substances listed in Annex XIV of the above regulation are used in the manufacture of PEFB 3060.

No substances listed in Annex XVII of the above regulation are used in the manufacture of PEFB 3060 with the exception of Polycyclic Aromatic Hydrocarbons (PAHs) which are encapsulated on the carbon black surface.

Polycyclic Aromatic Hydrocarbons (PAHs) are associated with carbon black and are present in trace levels on the surface of all carbon blacks. Hubron products fully encapsulate the carbon black pigment in a polymer matrix and as such any PAHs present are contained.

Typical total PAH content of carbon black grades used do not generally exceed 0.1% and levels of individual components such as benzo(a)pyrene varies considerable from grade to grade.

Annex XVII of Commission Regulation (EU) No 1272/2013 states that in certain applications where prolonged or short-term repetitive contact with human skin or the oral cavity is likely. The individual PAH content in a component should be lower than 1PPM. For toy applications, this is reduced further to 0.5PPM.

The above mentioned masterbatch contains 40% carbon black with the purity as specified above. Therefore, at the maximum masterbatch recommended dosage for food contact applications of 6.25%, the contribution of individual PAHs to a finished component is only 0.025PPM

Use of Perfluorooctanoic acid PFOA:

I can confirm that Hubron **do not** use PFOA, PFOS or any related substances (including salts and polymers) in the manufacture of PEFB 3060.

#### **Packaging and Packaging Waste Directive 94/62/EC**

Hubron masterbatches as listed below contain pigments with total levels of lead, cadmium, mercury and hexavalent chromium below 100PPM.

The above-mentioned materials are therefore in compliance with Article 11 of the above Directive

The above statement is unaffected by the amending Directives 99/177/EC, 2004/12/EC and 2005/20/EC.

#### **End-of Life Vehicle Directive 2000/53/EC**

The above mentioned masterbatches are NOT classified as hazardous as described, under directive (EU) 1272/2013. The above mentioned masterbatch only contains trace amounts of lead, mercury, cadmium and hexavalent chromium (<100PPM) unintentionally present.

Compliance with Directive 2000/53/EC of the European Parliament and of the Council of 18 September 2000 on end-of life vehicles, and its subsequent amendments 2002/525/EC, 2005/438/EC and 2005/673/EC must be determined by the end user.

#### **Persistent Organic Pollutants (EU) 2019/1021**

No substances listed in Annex I – IV are used in the manufacture of PEFB3060. Annex III states that PAHs should be subject to release reduction provisions.

PAHs are associated with carbon black and are present at trace levels on the surface of carbon black. The carbon black used in PEFB3060 meets the purity requirements outlined in (EU) 10/2011.

#### **2011/65/EU on the restriction of the use of certain hazardous substances in electrical and electronic equipment:**

Annex II of 2011/65/EU lists substances that have maximum permitted concentration values. Black Masterbatch PEFB 3060 does **not** contain the substances PBB or PBDE mentioned in Annex II of 2011/65/EU.

The above mentioned masterbatch does contain trace levels of Lead, Mercury, Cadmium and Chromium however, levels of individual substances should not typically exceed those indicated in Annex II of 2011/65/EU.

(EU) 2015/863 amends directive 2011/65/EU by listing a further 4 substances with maximum concentration values that are not to be exceeded. The above mentioned masterbatch does **not** contain any of the 4 substances listed (DEHP, BBP, DBP, DIBP)

#### **Phthalates in toys and childcare articles 2005/84/EC**

Black Masterbatch PEFB 3060 does not contain any of the phthalates DEHP, DBP, BBP, DINP, DIDP and DNOP as listed in the annex of the above directive.

The above mentioned masterbatch does not therefore contain any Phthalates and is compliant with the 22nd amendment of 76/769/EEC – 2005/84/EC

#### **Directive 2009/48/EC Safety of Toys & EN71**

Black Masterbatch PEFB 3060 is manufactured using raw materials in accordance with EN71-3:2013+A3:2018 in that they contain levels of heavy metals as listed in Table 2 'Migration limits from toy materials' that are lower

than the maximum permissible limits as indicated in the table for Category III materials, when the masterbatch is used at <6.25% addition level.

PEFB 3060 does not contain any substances listed in EN71-9:2005+A1:2007 and also complies to with changes to EN71-9 effective 4th November 2018 relating to Phenol content and migration.

PEFB 3060 does not contain any substances as intentionally added ingredients listed in Annex II of 2009/48/EC Section 3 part 11 relating to allergenic fragrances

#### **Regulation (EC) No 1223/2009 on Cosmetic Products**

PEFB 3060 does not contain any substances listed in Annex II and III of No 1223/2009 of substance not suitable for use in cosmetics.

Carbon black is listed in Annex IV of No 1223/2009 under colourants allowed in cosmetics products.

#### **GADSL**

This is to certify that no ingredients are listed in the GADSL Reference List revised 01/02/2020 with exception to Polycyclic Aromatic Hydrocarbons (PAH).

The individual PAH content in a component should be less than 1 PPM for any of the PAHs regulated by REACH Annex XVII. Data supplied by the carbon black producers of the specific grades used in PEFB 3060. shows that typical individual PAH levels do not exceed 1PPM. This information is based on occasional testing of the carbon black and does not form a specification/guaranteed level.

Testing should be carried out on the final article to confirm GADSL compliance, suggested recommended dosage <6.25%.

#### **Regulation (EU) No 528/2012 Biocidal Products**

PEFB 3060 does not contain any substances listed in the above regulation.

#### **Conflict Minerals**

The ingredients used constitutionally do not contain any derivatives:

- Gold
- Tin
- Tantalum
- Tungsten
- Wolframite
- Cassiterite
- Coltan
- Any other minerals or derivatives determined by the US Secretary of State to be financing conflict in the DRC or adjoining countries as stipulated in Section 1502 of the Dodd-Frank Act.

To clarify these conflict minerals are neither present in the raw materials we use, nor have they been intentionally added during the manufacturing process of the above mentioned masterbatch.

#### **North America:**

#### **FDA**

Not Compliant

#### **CONEG**

Hubron masterbatches as listed below contain pigments with total levels of lead, cadmium, mercury and hexavalent chromium below 100PPM. The above is therefore in compliance.

## California Proposition List 65 (December 18<sup>th</sup>, 2020 – Chemicals Known to the State to Cause Cancer or Reproductive Toxicity)

Black Masterbatch PEFB 3060 is based on a carbon black pigment which is listed. The carbon black is fully encapsulated and is **NOT** airborne or unbound. No other substances listed are present with the exception of trace levels of heavy metals and Polycyclic Aromatic Hydrocarbons (PAHs) where these quantities are within permissible limits.

### China:

#### Hygienic Standards for uses of additives in food containers and packaging materials (GB 9685-2016, 4806.6 and 4806.7)

The carbon black used in PEFB 3060 meets the purity requirements listed in Appendix A table A1 of GB9685-2016 with maximum content 'use appropriately according to the production demand'.

PEFB 3060 comprises a resin which is listed in PRC National Standard GB 4806.6-2016, Table A.1., entry 101 (CAS 9010-79-1) and complies with any applicable requirements for that resin, as tested with the above material or a comparable grade.

This material contains no monomers which are regulated with a restriction in their use.

This material does not contain additives which are regulated with a restriction in their use.

PEFB 3060 is suitable for producing articles suitable for food contact. Recommended maximum dosage is 6.25% w/w. PEFB 3060 has been manufactured according to the requirements laid down by the General Hygiene regulations GB 31603-2015.

### Japan:

PEFB 3060 is compliant with the Positive List, effective 28<sup>th</sup> April 2020 (MHLW Notification No 196) of substances related to food contact material in Japan, as mentioned in Section III of the Standards and specification for foods and food additives, Etc. (MHLW Notification No 370, effective June 2018) Under the food Sanitation Act (Act No 233 of 1947). We inform you that this Positive List is effective since 1<sup>st</sup> June 2020.

I confirm the polymers used in the manufacture of PEFB 3060 are listed in Table 1 (1) Base Polymer in the Category 40 (Polyethylene) with reference number 985 entry 4: ethylene homopolymer CAS 9002-88-4 and that the monomer used is listed in Table 1 (3) in Category 4 Hydrocarbon entry 5: ethylene CAS 74-85-1.

I can confirm that all additives (if any) used in the polymer carrier are listed on Table 2 and are below the permitted levels mentioned for Group 5.

整理番号 Ref. No.	通し番号 No.	物質名 Substance		CAS登録 番号 CAS Registry Number	食品区分 Food Category					最高温度 Maximum Temperature	合成樹脂区分 Synthetic Resin Group	特記事項 Requirements
		和名 Japanese Name	英名 English Name		酸性食品 Acidic	油脂及び脂 肪性食品 Fat/oil and fatty/oily	乳・乳製 品 Milk/milk product	酒類 Alcoholic beverage	その他の食 品 Others			
985	4	エチレン単独重合体	ethylene homopolymer	9002-88-4	○	○	○	○	○	III	5	

The carbon black used in the manufacture of PEFB3060 meets the purity requirements as outlined in JHOSPA.

### Others:

#### BSE/TSE

The above mentioned masterbatch is based on Polyethylene and contains a carbon black pigment. No additives are intentionally added. Information from suppliers confirms that these products are free from Bovine Spongiform Encephalopathy (BSE) and Transmissible Spongiform Encephalopathy (TSE).

Additionally, the raw materials used in the manufacture of PEFB 3060 are not derived from animal sources.

PEFB 3060 does not contain in the manufacture or as NIAS:

**2-Isopropyl-thioxanthone (ITX)**  
**2-Ethylhexyl-4-dimethylaminobenzoate (EHDAB)**  
**4-hydroxybenzophenon**  
**4-methylbenzophenon**  
**Allergens**  
**Antimony trioxide**  
**Benzophenon**  
**Bisphenol A [chemical name: 2,2-bis(4-hydroxyphenyl) propane] (CAS# 80-05-7)**  
**Chloramines**  
**Chlorine**  
**Dibutylamine**  
**diethanolamine**  
**diethylacetamide (DEA)**  
**diethylamine**  
**Diethylamine**  
**Dimethylamine**  
**Dinitrogen tetraoxide (N<sub>2</sub>O<sub>4</sub>)**  
**Dinitrogen trioxide (N<sub>2</sub>O<sub>3</sub>)**  
**Epoxidized soybean oil (ESBO)**  
**Formaldehyde**  
**HNO<sub>2</sub> (Nitrous Acid)**  
**HNO<sub>3</sub> (Nitric Acid)**  
**Latex**  
**Melamine**  
**Monoethylamine**  
**N,N-dimethylacetamide (DMA)**  
**N,N-dimethylformamide (DMF)**  
**NaNO<sub>2</sub> (Sodium Nitrite)**  
**NH<sub>2</sub>OH (Hydroxylamine)**  
**Nitrocellulose**  
**Nitrofurazone**  
**Nitrosamines**  
**Nitrosyl halides (e.g. ClNO, BrNO)**  
**N-Methylmorpholine (NMM)**  
**N-Methylpyrrolidine (NMP)**  
**N-Nitrosodiethylamine (NDEA) and N-Nitroso-N-methyl-4-aminobutyric acid (NMBA)**  
**N-Nitrosodimethylamine (NDMA),**  
**N-nitrosodiisopropylamine (DIPNA) i N-nitrosoethylisopropylamine (EIPNA).**  
**NO (Nitric Oxide)**  
**Organic nitrites (e.g. t-BuONO)**  
**Ozone**  
**secondary or tertiary amines, quaternary alkyl ammonium salts or alkyl amides**  
**Semicarbazide**  
**Tetra Butyl Ammonium Bromide (TBAB)**  
**Tributylamine (TBA)**  
**Triethylamine**

**Trimethylamine**

For Hubron



.....  
Mr R. Laurent – Technical Manager  
25<sup>th</sup> January 2021.

Hubron (Int) Ltd cannot be held responsible as a masterbatch producer, for the application in which the product is put by the converter/user. Overall and specific migration is another aspect of the commission regulation. This aspect often depends on the end use conditions, and it is the responsibility of the converter/user of the masterbatch to assure migration compliance of the final product for the intended usage conditions.

The information given above is true and accurate at the time given and it is based on documentation provided by raw material suppliers. Hubron holds no responsibility for the compliance of finished components or compounds, as additional processing and the use of other compound ingredients is beyond our control

# Quality Control

The quality assurance system of Primary Packaging Plastics is oriented towards a “zero defect strategy”. AQL values for dimensions must be within agreed specified limits. The necessary safety with respect to avoidance of dimensions out of specification (OOS) is achieved by means of process validation including risk analysis and/or in-line measurements and/or measurements on samples.

AQL values are defined on attributive characteristics according to below classification.

## Classification of defects

Classification of defect	Effects of defects	Defect class	AQL		Consequence
			Containers	Caps	
Critical	Critical defects are defects whose presence can have critical consequences. They can, for example: <ul style="list-style-type: none"> <li>• endanger human life or health</li> <li>• or violate legal requirements</li> <li>• or lead to destruction or alteration of filling material</li> <li>• or seriously impair the reliability of storage</li> <li>• or seriously impair the efficiency of production tools, filling and packaging equipment</li> </ul>	1	(*)	(*)	Packaging material not usable
Major	Major defects are defects whose presence can lead to considerable impairment. They can, for example: <ul style="list-style-type: none"> <li>• lead to inefficient function and thus to deficiency of the packaging material/pack</li> <li>• or lead to consumer complaint</li> <li>• or lead to reduced efficiency in production</li> <li>• or impair the efficiency of production tools, and filling and packaging equipment</li> </ul>	2A	0.25	0.1	Usability of packaging material markedly impaired
		2B	1.0	0.4	Usability of packaging material moderately impaired
Minor	Minor defects are defects whose presence do not have essential consequences, for instance they <ul style="list-style-type: none"> <li>• represent a reduction in general quality</li> </ul>	3	4.0	2.5	Usability of packaging material slightly impaired
		4	6.5	-	Usability of packaging material slightly impaired

(\*) No AQL value is defined for defect class 1 since for this defect class, tests are done against zero defects with the greatest possible certainty and/or manufacturing process is to be correspondingly validated. The necessary safety with respect to the avoidance of critical defects class 1 is achieved by means of process validation measures including risk analysis and/or in-line inspection and system checks. If defects of class 1 are found, it must be determined whether the entire batch or part of the batch is affected.

If a partial quantity containing a critical, major or minor defect can be clearly and reliably separated, the quality of the remainder of the batch must be evaluated separately.

## AQL values for IBM containers with special AQL values

Defects	Defect class
<ul style="list-style-type: none"> <li>- Raw material, primary packaging or labelling not according to specification</li> <li>- Mix-up</li> <li>- CFU exceeds specification</li> <li>- Shelf life exceeded</li> <li>- Moisture vapour transmission or light transmission or single internal reflectance or physicochemical OOS according to USP (white products only)</li> <li>- Migrations testing exceeds requirements for food contact material (white products only)</li> <li>- Contamination inside, contamination outside - can get into content</li> <li>- Tears, clefts, holes, incompletely moulded - function or tightness not ensured</li> <li>- Defects on sealing points - tightness impaired</li> <li>- Engraved/embossed text is missing or incorrect</li> </ul>	1
<ul style="list-style-type: none"> <li>- Foreign bodies incorporated in the material</li> <li>- Contamination outside on product - cannot get into content</li> <li>- Inhomogeneous colour</li> <li>- Deformation, not fully moulded, inhomogeneous distribution of material - usability markedly impaired</li> <li>- Flashes - usability markedly impaired</li> <li>- Wall thickness outside specifications</li> <li>- Black spots/degraded material <math>\leq 2</math> spots per container more than <math>&gt; 0.5</math> mm</li> <li>- Uneven surface</li> <li>- Bag with holes or incompletely welded</li> </ul>	2A
<ul style="list-style-type: none"> <li>- Defects on sealing points - tightness not impaired</li> <li>- Flashes - usability moderately impaired</li> <li>- Black spots/degraded material <math>\leq 2</math> spots per container</li> <li>- Black stripes in split line and bottom</li> <li>- Notches, clefts and roughness</li> </ul>	2B
<ul style="list-style-type: none"> <li>- Deformation - usability slightly impaired.</li> </ul>	3
<ul style="list-style-type: none"> <li>- Black spots/degraded material <math>\leq 1</math> mm</li> </ul>	4

*If a carton is damaged or soiled upon arrival, the error should be noted at arrival on the shipping documents and the carton discarded. The remaining part of the batch is to be received as normal goods.*

## Quality control for IBM containers with special AQL values

Activity	Control
Incoming control of raw materials	Identification of goods received and control of certificates.
Set-up new mould or change of raw materials or control specification	<b>Line clearance</b> including control of correct use of raw materials. Three samples of each cavity produced at the same time are visually controlled as well as checked for critical dimensions with plug-and ring gauges by production and QC prior to production start.
Production	<p>QC operator performs a <b>visual control</b> of the products in accordance with ISO 2859-1. The samples are taken every hour (one sample per cavity produced at the same time). A sample of each cavity is checked for critical dimensions with plug-and ring gauges every second hour.</p> <p>New approval by production and QC is required after <b>machine stops</b> lasting more than one hour.</p> <p>In case of unplanned machine stops where products can be defected the products are 100% controlled or scrapped.</p> <p>If defects are detected, products are quarantine stored or 100% controlled.</p>
Quality control	<p>QC <b>reviews all the production documentation</b> and point out products that need additional control. This also includes follow-up on products which are quarantine stored by production.</p> <p>QC <b>controls the dimensions</b> of the samples from two of the in-process controls with plug-and ring gauges.</p> <p>QC controls the pallets for mix-up and incorrect labelling, releases the products and issue certificates with the results of the controls.</p>

# Declaration of Conformity

## European Pharmacopoeia (EP)

Declaration concerns all products manufactured in Gerresheimer Vaerloese A/S with the following composition:

- **GF 4760 / Colored**

Based upon certificate from our supplier of the above mentioned resin, Gerresheimer Vaerloese A/S hereby states that the resin complies with the European Pharmacopoeia, paragraph 3.1.3 “Polyolefines”, 3.1.5 “Polyethylene with additives for containers for preparations for parenteral use and for ophthalmic preparations”.

The masterbatches used during production comply with the relevant regulations related to plastic materials intended to come into contact with food however the suppliers do not declare the material to be in compliance with the European Pharmacopoeia.

Gerresheimer Vaerloese A/S additionally informs that our packages dedicated for solid oral dosage forms and solid active substances are tested in accordance with food law. For such substances, it has been agreed by the Joint Committee for Medicinal Products for Human Use / Committee for Medicinal Products for Veterinary Use Quality Working Party that plastic materials compliant with the relevant European Union (EU) food legislation relating to plastic materials and articles intended to come into contact with foodstuffs are considered acceptable.

Yours sincerely,



Marta Slocka-Momotiuk  
Compliance Specialist

Primary Packaging Plastics

# Declaration of Conformity

## European Union (EU) Food Contact

Based upon the certificates from the suppliers of the resins and/or masterbatches, Gerresheimer Vaerloese A/S hereby confirms that raw materials used in production of below mentioned products:

- Dudek Cap colored,
- Duma Handy Cap colored,
- Duma Handy Cap with Integrated Desiccant colored,
- Duma MG Cap colored,
- Duma Multi Grip Cap colored,
- Duma Special Container colored,
- Duma Standard Container colored,
- Duma Twist-Off with Desiccant, colored,
- Duma Twist-Off Cap colored,
- Duma Pocket colored,
- Duma Pocket Base colored,
- Duma MG Container colored

Comply with relevant requirements of Regulation 1935/2004/EC on materials and articles intended to come into contact with food (Framework Regulation); Regulation 2023/2006/EC on good manufacturing practice for materials and articles intended to come into contact with food (GMP) and Regulation 10/2011/EC (PIM) on plastic materials and articles intended to come into contact with food.

Yours sincerely,



Marta Slocka-Momotiuk  
Compliance Specialist

Primary Packaging Plastics

April 27, 2021

## Declaration of Conformity

Primary Packaging Plastics requires from all raw materials suppliers to inform about any animal derived substances used for production of their products and also requests from suppliers to consider and fulfill the relevant regulations of the European Community about the avoidance of TSE/BSE contamination.

If applicable, all suppliers are requested to fulfil the requirements:

- The animal derived substances used for the manufacturing of their polymers are either produced from animals originating from BSE-free countries or are free from SRM (specified Risk Material).
- The manufacture of the animal derived substances involves rigorous processes that meet/exceed the very severe process conditions for inactivating any BSE/TSE agent.

If any of raw materials contain ancillary materials based on fatty acid, such fatty acids might have a number of origins from for example plants, animal or synthetic, where the animal origin is the most common. The use of these subsidiaries as ancillary materials, including packaging for the pharmaceutical-and the foodstuff industries, are regulated through a number of EU directives. Tallow derived materials used in some product fulfill the requirements laid down in the Regulations 1069/2009/EC, and 142/2011/EC, and the "Note for Guidance EMEA/410/01, rev. 3". These directives regulate the general use of these products and specifically security against BSE to transmit to pharmaceutical-or foodstuff products.

Primary Packaging Plastics has received statements or certificates from all suppliers, where they state that:

- their products do not contain specific material of risk (SRM) and that infection does not transmit via their products, or
- their products fulfilled all requirements laid down in relevant regulations concerning BSE/TSE substances.

Yours sincerely,



Marta Słocka-Momotiuk  
Compliance Specialist  
Primary Packaging Plastics

April 14, 2020

## Declaration of Conformity

Primary Packaging Plastics only process raw materials delivered from suppliers and does not add any additional materials to such raw materials. Based upon certificates from raw materials suppliers, Primary Packaging Plastics hereby confirms that:

- Allergens
- Latex
- Melamine
- Bisphenol A
- Phthalates

have not been intentionally added during their production. However, the fact that these substances are not used in these products does not exclude that trace levels of them may be present as a result of the specific characteristics of raw materials and/or of the manufacturing process. Please note that, in any case suppliers do not carry out any specific analyses in order to detect the presence of above mentioned substances.

The information is given to the best of our knowledge and does not include any warranty whatsoever. It must therefore not be misunderstood as guaranteeing specific properties. End-customers have to decide at their own discretion about the suitability of our products for their purposes, based on the explicit descriptions in our product specifications.

Yours sincerely,



Katarzyna Jawor  
Compliance Specialist  
Primary Packaging Plastics

# DECLARATION OF CONFORMITY

**Gerresheimer Vaerloese A/S  
Walgerholm 2-8  
3500 Værløse, Denmark**

Gerresheimer Vaerloese A/S has taken appropriate precautions to reduce the risk for TBA (2,4,6-tribromoanisole) and TCA (2,4,6-trichloroanisole) contamination of products supplied to our customers.

TBA with a threshold of 0.02 PPT and TCA with a threshold of 1 PPT do not introduce any toxicological risks but can have impact in musty molded odor.

Risk for TBA/TCA contamination is included into the risk analysis for the whole manufacturing and handling/storage process in the plant and all wooden pallets used for raw materials, component and final products are heat treated and comply with ISPM 15.

Gerresheimer Vaerloese A/S can only be held responsible for any odor issues due to TBA and/or TCA contamination, if it can be proven that the contamination of the primary plastic packaging has happened before shipment of the products.

Værløse, April 16<sup>th</sup>, 2020



Christina D. Holder  
Quality Manager

# Customer Complaint Report

<input type="checkbox"/> Complaint <input type="checkbox"/> Comment / Remark  Customer report No:	Established by / date:
Customer name / address / country:	Contact person / E-mail / Fax no.:
Article no.:	Date of delivery:
Batch no.:	Invoice no.:
Cavity no.:	Order no.:
Number of defective items:	Total quantity delivered:
Defect observed in: <input type="checkbox"/> Incoming control.....    Sample size: <input type="checkbox"/> Production.....    Quantity of items used: <input type="checkbox"/> Final product(s).....    Quantity of items used: <input type="checkbox"/> Complaint from end-user	
Defect found in: <input type="checkbox"/> One carton <input type="checkbox"/> Several cartons: Quantity _____	Exact production date/time from carton/bag or carton/bag/pallet number:  <input type="checkbox"/> Not available
Are filled/not filled products quarantined: <input type="checkbox"/> Yes – Quantity (filled): <input type="checkbox"/> Yes – Quantity (not filled): <input type="checkbox"/> No <input type="checkbox"/> N/A – no products left	Samples: <input type="checkbox"/> Will be sent <input type="checkbox"/> Not available <input type="checkbox"/> Additional information will be forwarded
Description of defect:	

Received by QA dept. (init. / date): \_\_\_\_\_

## Information requested in relation to complaint investigation

We will kindly ask you to supply us with the answers to the below listed questions. The information is important for us, to make a thorough investigation.

Please return the information as soon as possible, so that we can initiate our investigation.

### Labelling

Company name:	Today's date:
<input type="checkbox"/> Wrong information <input type="checkbox"/> Missing information <input type="checkbox"/> Missing label <input type="checkbox"/> Label difficult to read	
<input type="checkbox"/> Samples have been send <input type="checkbox"/> Samples will be send <input type="checkbox"/> Pictures are available <input type="checkbox"/> No samples or pictures are available	
The defect is observed in <input type="checkbox"/> One bag/carton <input type="checkbox"/> Several bags/cartons - Quantity	
Exact production date and time for all concerned bags	
Exact quantity of defective items/bags/cartons	
How many bags/cartons have been controlled	
Amount of products blocked	
Comments:	

## Information requested in relation to complaint investigation

We will kindly ask you to supply us with the answers to the below listed questions. The information is important for us, to make a thorough investigation.

Please return the information as soon as possible, so that we can initiate our investigation.

### Loose silica gel / loose desiccant / defect on desiccant

Company name:	Today's date:
<input type="checkbox"/> Samples have been send <input type="checkbox"/> Samples will be send <input type="checkbox"/> Pictures are available <input type="checkbox"/> No samples or pictures are available	
Defect observed in: <input type="checkbox"/> Upon reception at your warehouse <input type="checkbox"/> Incoming inspection - sample size/plan: _____ <input type="checkbox"/> Observed in PDS <input type="checkbox"/> Before filling/when opening the cartons <input type="checkbox"/> Before filling/on your line <input type="checkbox"/> After filling <input type="checkbox"/> Market complaint	
Defect observed in <input type="checkbox"/> One bag <input type="checkbox"/> Several bags - Quantity	
Exact production date and time for all concerned bags	
Exact quantity of defective items	
Are there any signs of damage to cap, desiccant or cardboard	
Are there any signs of transport damage to bag or carton	
Quantity of item used or controlled from the batch	
Amount of products blocked	
Amount of filled products blocked	
Comments:	

## Information requested in relation to complaint investigation

We will kindly ask you to supply us with the answers to the below listed questions. The information is important for us, to make a thorough investigation.

Please return the information as soon as possible, so that we can initiate our investigation.

### Mix-up

Company name:	Today's date:
Ordered product	
Product received	
How many bags/cartons have been controlled	
Amount of products blocked	
Production date and time of all the concerned bags/cartons	
<input type="checkbox"/> Samples have been send <input type="checkbox"/> Samples will be send <input type="checkbox"/> Pictures are available <input type="checkbox"/> No samples or pictures are available  For for mix-up - both carton label and bag label is important – and it would be helpful, if the pictures also showed the production date/time.	
Comments:	

## Information requested in relation to complaint investigation

We will kindly ask you to supply us with the answers to the below listed questions. The information is important for us, to make a thorough investigation.

Please return the information as soon as possible, so that we can initiate our investigation.

### Partly- or disconnected TE-rings

Company name:	Today's date:
<input type="checkbox"/> Samples have been send <input type="checkbox"/> Samples will be send <input type="checkbox"/> Pictures are available <input type="checkbox"/> No samples or pictures are available	
Quantity of caps with disconnected TE-rings	
Quantity of caps with partly disconnected TE-rings <i>Please specify quantity of broken bridges according to the AQL values/specification.</i>	
Specific cavity number affected	
Defect observed in: <input type="checkbox"/> Incoming inspection - sample size/plan: _____ <input type="checkbox"/> Observed in PDS <input type="checkbox"/> Before filling/when opening the cartons <input type="checkbox"/> Before filling/on your line <input type="checkbox"/> After filling <input type="checkbox"/> Market complaint	
Quantity of item used or controlled from the batch	
Amount of products blocked	
Amount of filled products blocked	
Defect observed in <input type="checkbox"/> One bag/carton <input type="checkbox"/> Several bags/cartons - Quantity	
Exact production date and time for all concerned bags	
Are there signs of damage to the cap/bag/carton	
Comments:	

## Information requested in relation to complaint investigation

We will kindly ask you to supply us with the answers to the below listed questions. The information is important for us, to make a thorough investigation.

Please return the information as soon as possible, so that we can initiate our investigation.

### Product defect

Company name:		Today's date:	
<input type="checkbox"/> Samples have been send <input type="checkbox"/> Samples will be send <input type="checkbox"/> Pictures are available <input type="checkbox"/> No samples or pictures are available			
Defect observed in: <input type="checkbox"/> Upon reception at your warehouse <input type="checkbox"/> Incoming inspection - sample size/plan: _____ <input type="checkbox"/> Observed in PDS <input type="checkbox"/> Before filling/when opening the cartons <input type="checkbox"/> Before filling/on your line <input type="checkbox"/> After filling <input type="checkbox"/> Market complaint			
Exact quantity of defective items			
Specific cavity number affected			
Quantity of item used or controlled from the batch			
Amount of products blocked			
Amount of filled products blocked			
Defect observed in <input type="checkbox"/> One bag <input type="checkbox"/> Several bags – Quantity			
Exact production date and time for all concerned bags			
Comments:			

## Information requested in relation to complaint investigation

We will kindly ask you to supply us with the answers to the below listed questions. The information is important for us, to make a thorough investigation.

Please return the information as soon as possible, so that we can initiate our investigation.

### Transport

Company name:	Today's date:
<input type="checkbox"/> Pictures are available <input type="checkbox"/> No pictures are available	
<input type="checkbox"/> A copy of the CMR ("Proof of delivery" from the transporter) has been forwarded <input type="checkbox"/> A copy of the CMR ("Proof of delivery" from the transporter) will be forwarded <input type="checkbox"/> The CMR ("Proof of delivery" from the transporter) is not available	
Defect observed on <input type="checkbox"/> One carton <input type="checkbox"/> Several cartons	
Exact quantity of damaged cartons	
Products can be used	<input type="checkbox"/> yes / <input type="checkbox"/> No
Comments:          	