	Printed, the document is not a controlled document.		Level:
	<b>006017-41A0 Duma Handy Cap</b>		Approved by: <b>CDH 2021.05.11</b>
	Document owner: <b>VriQM</b>	Version: <b>6.17</b>	Implementation: <b>2021.05.11</b>
Document users:	Document no.: <b>1. 4.3.9</b>	Standard Product Database	

## Product Specification and Certificate

<b>Product no.</b>	006017-41A0
<b>Product name</b>	Duma Handy Cap 6017
<b>Product description</b>	65 mm round plastic push-fit tamper-evident cap with a short opening tear-band and frangible connecting bridges. Intended for the sealing of: - Duma Special 150 - 500 ml HDPE Containers Intended for packaging of tablets and powder for Pharmaceutical use.
<b>Design</b>	<ul style="list-style-type: none"> <li>Regulatory drawing <a href="#">A006017 Coloured Regulatory</a></li> <li>Standard drawing <a href="#">B006017 Coloured</a></li> </ul>
<b>Raw material</b>	LD 653, Low-density polyethylene (LDPE) in compliance with Commission Regulation (EU) No 10/2011, FDA title 21 CFR § 177.1520 "Olefin Polymers" and BfR recommendation III "Polyethylen", ExxonMobil. Coloured with black masterbatch. <a href="#">LD653 Declaration</a>
<b>Colour</b>	18-2440-PBL-7 - Black, Polyethylene (PE) in compliance with Commission Regulation (EU) No 10/2011, Kunststoff-Kemi A/S. Slip agent: 11760301, LyondellBasell (formerly (A. Schulman) or CESA-slip PE 10227, Avient (formerly Clariant) in compliance with Commission Regulation (EU) No 10/2011 and FDA title 21 CFR § 177.1520. <a href="#">18-2440-PBL-7 Declaration (supplier's productname PEFB3060)</a> <a href="#">11760301 Declaration</a> <a href="#">PE 10227 Declaration</a>
<b>Production</b>	<b>Facility:</b> Haarby, Denmark <b>Process:</b> The caps are injection moulded <b>Hygiene:</b> The production takes place in clean room <b>Sterilisation:</b> N/A

## Measures and Properties

<b>Dimensions:</b>			
External:		Internal:	
Height	19.7 +0.5/-0.5 mm	Diameter	59.5 +0.3/-0.2 mm
Diameter	64.5 +0.5/-0.6 mm	Base ring	60.8 +0.3/-0.4 mm
Max. width	69.0 mm	Sealing plug	54.2 +0.2/-0.2 mm
<b>Other dimensions:</b>			
Weight	9.0 +0.8/-0.8 g	Shelf life	5 years
		Bioburden	Max. 50 CFU

## Test Results

Moisture Vapour Transmission and Light Transmission tests are only carried out on products with white masterbatch.
--

	Printed, the document is not a controlled document.		Level:
	<b>006017-41A0 Duma Handy Cap</b>		Approved by: <b>CDH 2021.05.11</b>
	Document owner: <b>VriQM</b>	Version: <b>6.17</b>	Implementation: <b>2021.05.11</b>
Document users:	Document no.: <b>1. 4.3.9</b>	Standard Product Database	

Single Internal Reflectance and Physicochemical Test are only carried out on products with white masterbatch.

### Packing and Way of Delivery

The products are packed in 1 PE bag, which is then heat-sealed. The PE bag is put into a cardboard carton, which is sealed with PP-tape. The cartons are packed on pallets, which are 1200 x 800 x 140 mm and weight approximately 23 kg.

#### Carton dimensions:

Height (mm): 340                      Length (mm): 580                      Width (mm): 385

#### Packing information:

Number of items per carton: 800                      Volume per carton (m<sup>3</sup>): 0.08  
 Max. number of cartons per pallet: 20                      Weight per carton (kg.): 8.0  
 Max. height of the pallet (mm): 1900

### Labelling

Each carton is provided with a label with the following information:

- Manufacturer name
- Material name and number
- Batch / lot number and quantity
- Customer information (if requested)
- Country of origin
- Shelf life
- Production date and machine number

### Recommendation to Storage, Handling and Transportation

Stored inside in clean conditions in its original un-open packaging, protected from direct sunlight and with a temperature between 5 - 35° C and Relative Humidity between 30 - 70 %.

### Quality Control

All products are quality controlled according to instructions specified in our quality control system. We therefore guarantee that all deliveries from Primary Packaging Plastics have passed our control procedures and comply with the quality demands mentioned below. If required a certificate of conformance can be issued. The classification of defects and specifications of AQL values are based on ISO 2859 and Quality Assurance of Pharmaceutical and Cosmetic Packaging Materials:  
 Defect Evaluation List for Blow-moulded Plastic Containers Vol. 23 - ISBN 3-87193-405-6.  
 Defect Evaluation List for Injection-moulded parts made of Plastic: Closures, Sealing Disks and dosage aids (droppers, etc.) Vol. 22 - ISBN 3-87193-182-9.  
 Documentation enclosed.  
[Quality Control - Handy Cap](#)

### Declaration of Conformity

- [DoC EP \(LD653 Colored\)](#)
- [DoC Food Law- colored](#)
- [DoC TSE/BSE](#)
- [DoC Allergens, Phthalates, BPA, Latex, Melamine](#)
- [DoC TBA\\_TCA](#)

	Printed, the document is not a controlled document.		Level:
	<b>006017-41A0 Duma Handy Cap</b>		Approved by: <b>CDH 2021.05.11</b>
	Document owner: <b>VriQM</b>	Version: <b>6.17</b>	Implementation: <b>2021.05.11</b>
Document users:	Document no.: <b>1. 4.3.9</b>	Standard Product Database	

### Information on Packaging and Packaging Waste Directive 94/62/EC and/or CONEG

Both container, cap and bag are produced from material, which complies with the directions for plastics material in contact with foodstuffs. The content of heavy metals in the products, the inner bag, and the carton is less than 100 ppm.  
The packaging is recyclable for material recovery and/or well suited for energy recovery due to its high energy density. Reuse is technically possible depending on applicable regulations.

### REACH

We can confirm that the raw materials used in the product are either pre-registered or exempted from pre-registration.

### Complaint Handling

In case that the delivered products are outside specification, complaint must be send in writing to daily contact person in Customer Care Center.

In order to ensure a thorough investigation it is important to send the following basic information:

- Article number
- Batch number
- Cavity number (if related to specific cavities)
- Number of defective items
- Defect observed in
  - a) incoming control including sample size
  - b) production including quantity of items used
  - c) final products including quantity of items used
  - d) market complaint
- Defect found in
  - a) one carton
  - b) several cartons - please specify quantity
- Exact production date/time from carton/bag or carton/bag/pallet number products in quarantine:
  - a) Filled products - Quantity
  - b) Not filled products - Quantity
  - c) No products left
- Description of the defect

The following standard form can be used: 3.1 Customer Complaint Report.

Depending on the defect, additional information will be requested as described in the attached standard forms: 2.5 Information requested in relation to complaints.

It is very important to send samples at the time a complaint is filed, as any delay in these can have an impact on time of investigation. An investigation report is send to Customer within 21 days counting from when complaint, relevant information and samples are received.

#### Important !

Filled or empty products involved in a complaint to Primary Packaging Plastics, must only be destroyed by Customer after written approval from Gerresheimer.

	Printed, the document is not a controlled document.		Level:
	<b>006017-41A0 Duma Handy Cap</b>		Approved by: <b>CDH 2021.05.11</b>
			Implementation: <b>2021.05.11</b>
Document owner: <b>VriQM</b>			
Version: <b>6.17</b>			
Document users:	Document no.:	Standard Product Database	
	<b>1. 4.3.9</b>		

Any activity in connection with a complaint where Customer expect Gerresheimer to cover the costs must be approved by Gerresheimer in writing before initiation of the activity.

[Complaint report](#)

[Labelling](#)

[Loose silica gel-loose desiccant-defect on desiccant](#)

[Mix-up](#)

[Partly- or disconnected TE-rings](#)

[Product defect](#)

[Transport](#)

## Registrations and Certifications

**Primary Packaging Plastics was established in 2020. Before that time the company was working under the following names: Gerresheimer Plastic Packaging, Superfos Pharma, Superfos Pharma Pack, Dudek Plast and Duma.**

Documentation, i.e. test reports, certificates etc. issued before July 2020 will be with reference to one of the names above.

**Gerresheimer Vaerloese A/S has obtained the following registrations and certifications for Vaerloese and Haarby, Denmark:**

ISO 9001, no. 160454-2014-AQ-DEN-DANAK

ISO 14001, no. 156579-2014-AE-DEN-DANAK

ISO 15378, no. 160455-2014-Q-DEN-DNV

ISO 45001, no. 10000341648-MSD-DANAK-DNK

**The product is registered in Russia with the following number:**

C3 2011/11203 – plastic packages in size between 3ml to 3000 ml with accessories.

## Revisions

Version:	Implementation:	Revision information:
<a href="#">1</a>	2010.02.08	Transfer to new system and additional information
<a href="#">2.1</a>	2010.11.07	Recorrection of version number from 1.0 to 2.1
<a href="#">2.2</a>	2011.03.01	LD653 Declaration 2010: Updated LD653 declaration
<a href="#">2.3</a>	2011.10.05	LD653 Declaration 2011: Updated LD653 declaration LD 653 - Black: LD 653 declaration updated
<a href="#">2.4</a>	2012.01.31	Registrations and Certifications: More precise description of registrations
<a href="#">2.5</a>	2012.03.24	PE 10227 Declaration: Updated
<a href="#">2.6</a>	2012.05.29	Hrb IM caps: Production takes place in clean room
<a href="#">2.7</a>	2013.02.01	EP Statement - LD653 / PPH 10012 / PPC 10712: Declaration of Conformity updated
<a href="#">2.8</a>	2013.04.08	LD653 Declaration 2013: Updated
<a href="#">2.9</a>	2013.06.03	PE 10227 Declaration 2013: Updated
<a href="#">3</a>	2013.08.30	LDPE bag is heat-sealed. 1000052 declaration updated

	Printed, the document is not a controlled document.		Level:
	<b>006017-41A0 Duma Handy Cap</b>		Approved by: <b>CDH 2021.05.11</b>
	Document owner: <b>VriQM</b>	Version: <b>6.17</b>	Implementation: <b>2021.05.11</b>
Document users:	Document no.: <b>1. 4.3.9</b>	Standard Product Database	

3.1	2014.01.13	100052 Declaration 2013: Updated with FDA 18-2440-PBL-7 Declaration 2013 (supplier's productname PEFB3060): Updated
3.2	2014.07.08	18-2440-PBL-7 Declaration (supplier's productname PEFB3060): Updated with Regulation 202/2014
3.3	2014.08.07	LD653 Declaration 2014: Updated
3.4	2014.11.03	Kunststof-Kemi 18-2440-PBL-7 + Slip: Ferro changed name to A. Schulman. Regulation (EU) 10/2011
3.5	2015.03.23	LD653 Declaration: Updated with Reg. (EU) No 2015/174
3.6	2015.10.21	PE 10227 Declaration : Updated
3.7	2016.04.08	Kunststof-Kemi 18-2440-PBL-7 + Slip: Clariant new company name
3.8	2016.05.10	Registrations and Certifications: Updated
3.9	2016.06.14	PE 10227 Declaration : Updated
4	2016.06.24	Regulatory drawing, Declaration of Conformity and Complaint handling added
4.1	2016.06.29	Quality Control - General text: New classification of defects Quality Control - Duma Handy Cap Haarby: Updated
4.2	2016.08.11	11760301 Declaration 2016: Updated
4.3	2016.08.12	Kunststof-Kemi 18-2440-PBL-7 + Slip: A. Schulman new article number
5	2016.09.16	Information regarding USP tests updated
5.1	2016.09.26	11760301 Declaration 2016: Updated with 1416/2016
5.2	2016.11.10	Physico/In vitro - Not white: Wording changed
5.3	2016.12.08	18-2440-PBL-7 Declaration (supplier's productname PEFB3060): Updated
5.4	2016.12.12	PE 10227 Declaration 2016: Updated
5.5	2017.02.07	LD653 Declaration: Updated
5.6	2017.04.03	Containers and Caps HRB: Packed in PE bag
5.7	2017.05.10	B006017: Updated A006017 Regulatory: Updated
5.8	2017.05.15	Added declaration TBA/TCA
5.9	2017.05.24	B006017: Correction of link to drawing A006017 Regulatory: Correction of link to drawing
5.10	2017.06.08	11760301 Declaration: Updated with 2017/752
5.11	2017.10.03	PE 10227 Declaration: Updated with 2017/752
5.12	2017.10.20	LD653 Declaration: Updated with 2017/752
5.13	2017.10.26	DoC TSE/BSE: Updated (yearly update)
5.14	2017.11.28	DoC Allergens, Phthalates, BPA, Latex, Melamine: Yearly update
5.15	2018.02.21	11760301 Declaration: Updated with 2018/79
5.16	2018.02.27	PE 10227 Declaration: Updated
5.17	2018.03.20	LD653 Declaration: Updated with 2018/79
5.18	2018.03.22	LD653 Declaration: Updated
5.19	2018.04.03	18-2440-PBL-7 Declaration (supplier's productname PEFB3060): Updated with 79/2018
5.20	2018.09.12	11760301 Declaration: Updated with New SVHC list
5.21	2018.11.05	LD653 Declaration: Updated with 831/2018
5.22	2018.11.19	PE 10227 Declaration: Updated with 2018/831

	Printed, the document is not a controlled document.		Level:
	<b>006017-41A0 Duma Handy Cap</b>		Approved by: <b>CDH 2021.05.11</b>
	Document owner: <b>VriQM</b>	Version: <b>6.17</b>	Implementation: <b>2021.05.11</b>
Document users:	Document no.: <b>1. 4.3.9</b>	Standard Product Database	

5.23	2019.02.11	PE 10227 Declaration: Updated with 37/2019
5.24	2019.02.21	Registrations and Certifications with FDA,TPD, Russia and China: Updated - China registration.
5.25	2019.03.04	11760301 Declaration: Updated with 37/2019
5.26	2019.03.25	DoC TSE/BSE: Yearly update DoC Allergens, Phthalates, BPA, Latex, Melamine: Yearly update
5.27	2019.03.27	DoC EP (LD653 Colored): Yearly update
5.28	2019.04.30	IR/DSC - Not white: Text updated
5.29	2019.09.03	Labelling: Updated
5.30	2020.01.28	DoC Food Law- colored: Updated with MG Container colored
5.31	2020.02.06	LD653 Declaration: Yearly updated
5.32	2020.03.24	DoC TSE/BSE: Yearly updated
5.33	2020.04.06	DoC EP (LD653 Colored): Yearly update.
5.34	2020.04.14	DoC TSE/BSE: Updated name to Primary Packaging Plastics DoC Allergens, Phthalates, BPA, Latex, Melamine: Updated name to Primary Packaging Plastics
5.35	2020.04.15	Registrations and Certifications with FDA,TPD, Russia and China: Updated name to Primary Packaging Plastics
5.36	2020.04.16	DoC TBA_TCA: Updated
5.37	2020.04.20	DoC EP (LD653 Colored): New division name_Primary Packaging Plastic
5.38	2020.04.29	Complaint handling: New division name_Primary Packaging Plastic
5.39	2020.06.05	DoC EP (LD653 Colored): Updated
5.40	2020.06.17	B006017 White: Updated A006017 White Regulatory: Updated
6	2020.06.19	Drawing, measures and registrations updated
6.1	2020.08.18	Registrations and Certifications with Russia: ISO 45001 obtained
6.2	2020.08.25	Quality Control - General text: Updated name Primary Packaging Plastics
6.3	2020.09.17	PE 10227 Declaration: Yearly updated 18-2440-PBL-7 Declaration (supplier's productname PEFB3060): Updated SVHC List_25.06.2020
6.4	2020.09.23	11760301 Declaration: Yearly updated
6.5	2020.09.27	Kunststof-Kemi 18-2440-PBL-7 + Slip: Clariant name change to Avient
6.6	2020.09.30	11760301 Declaration: With FDA status
6.7	2021.01.26	LD653 Declaration: Yearly updated, also with SVHC list 19.01.2021, japanese food law Kunststof-Kemi 18-2440-PBL-7 + Slip: A. Schulman name change to LyondellBasell 18-2440-PBL-7 Declaration (supplier's productname PEFB3060): Updated SVHC list 19.01.2021
6.8	2021.03.03	Quality Control - Handy Cap: Updated with Primary Packaging Plastics
6.9	2021.04.15	DoC EP (LD653 Colored): Yearly update and change of company logo
6.10	2021.04.16	

	Printed, the document is not a controlled document.		Level:
	<b>006017-41A0 Duma Handy Cap</b>		Approved by: <b>CDH 2021.05.11</b>
	Document owner: <b>VriQM</b>	Version: <b>6.17</b>	Implementation: <b>2021.05.11</b>
Document users:	Document no.: <b>1. 4.3.9</b>	Standard Product Database	

		DoC Food Law- colored: Yearly update and change of company logo
6.11	2021.04.22	Labelling Loose silica gel-loose desiccant-defect on desiccant
6.12	2021.04.23	Packing and Packing waste directive: Updated. Partly- or disconnected TE-rings Product defect Transport
6.13	2021.04.27	Complaint report DoC TSE/BSE: Change of company logo
6.14	2021.05.04	Mix-up
6.15	2021.05.07	Labelling
6.16	2021.05.10	Loose silica gel-loose desiccant-defect on desiccant Mix-up Partly- or disconnected TE-rings Product defect Transport
6.17	2021.05.11	Complaint report

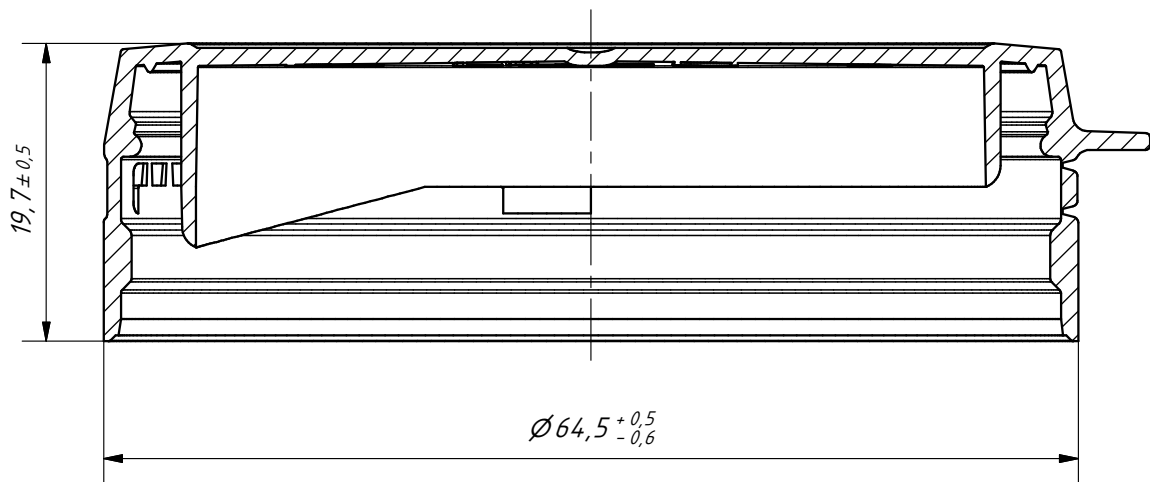

			<b>GERRESHEIMER</b>	
Replaced drawing			Gerresheimer Vaerloese A/S Walgerholm 2-8, Postbox 229 DK-3500 Vaerloese	
Designer	Hek	15.05.2020	Phone +45 4477 7888 Fax. +45 4477 7892	
Released	BS	15.05.2020	This drawing may not be handed over, copied or used by others	
Scale	Drawing Type	Size	Item <b>Duma Handy Cap 006017 Coloured</b>	No. <b>A006017 Coloured</b>
2 : 1	Regulatory	A 4		Vers. no.: <b>1</b>

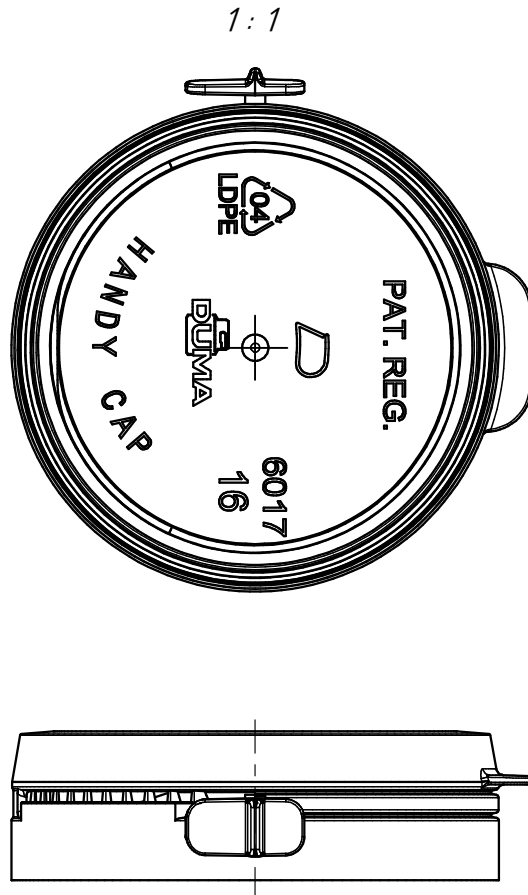
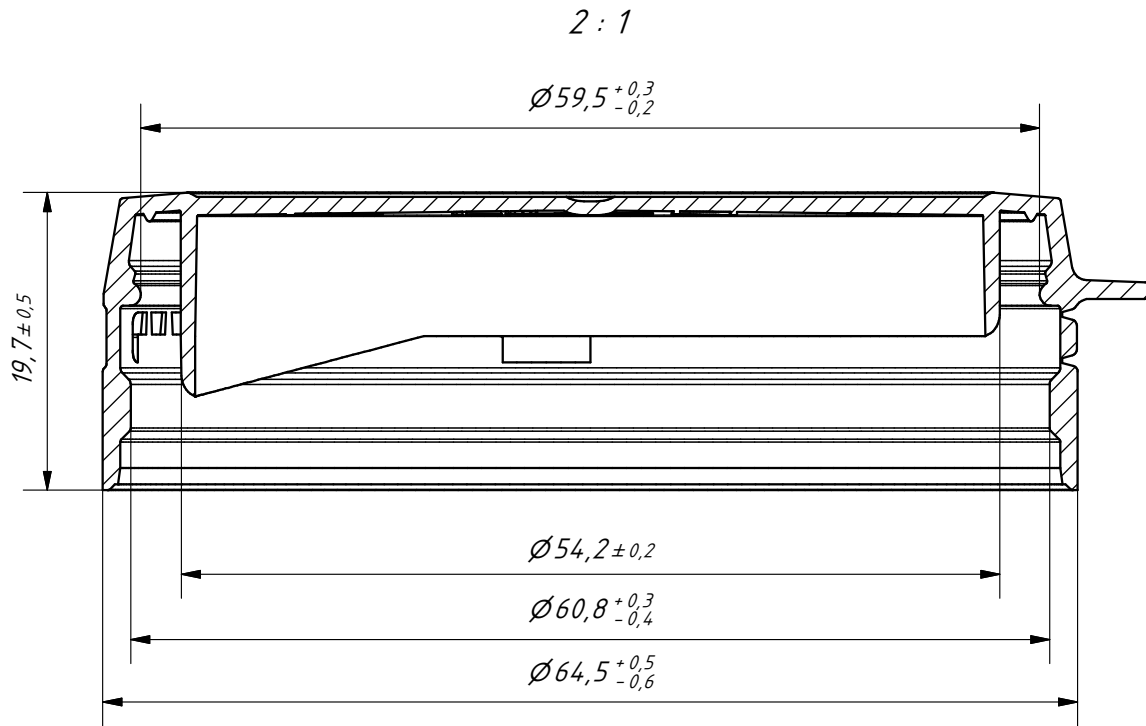

			<b>GERRESHEIMER</b>	
Replaced drawing			Gerresheimer Vaerloese A/S	Phone +45 4477 7888
Designer	Hek	15.05.2020	Walgerholm 2-8, Postbox 229	Fax. +45 4477 7892
			DK-3500 Vaerloese	
Released	BS	15.05.2020	This drawing may not be handed over, copied or used by others	
Scale	Drawing Type	Size	Item Duma Handy Cap 006017 Coloured	No. B006017 Coloured
2 : 1	Standard	A 4		Vers. no.: 1

RAVAGO DISTRIBUTION SA  
Guy Buekenhout  
PEGASUS POLYMERS NV  
MOERENSTRAAT 85A  
2370 ARENDONK  
Belgium  
Email Address: [guy.buekenhout@pegasuspolymer.com](mailto:guy.buekenhout@pegasuspolymer.com)

Issue Date: 26 Jan 2021

Dear Sir/Madam:

In response to your request, please find enclosed the product regulatory summary for requested product.

If you have any questions or need additional information please contact your ExxonMobil sales representative.

ExxonMobil™ LDPE LD 653 EUROPE  
Reference ID: PRS0000036364\_C

**Product Name: ExxonMobil™ LDPE LD 653**

**Manufacturing Region: EUROPE**

## Category: Food Regulations

### CANADA FOOD CONTACT REGULATIONS (HPFB)

With regard to the compliance status of the ExxonMobil Chemical product referenced above with the regulation(s) identified below the following can be declared:

A "Letter of No Objection" has been received from the Canadian Health Products and Food Branch (HPFB) for this product. Contact your Sales representative to request a Letter of Authorization.

### CHINA FOOD CONTACT REGULATIONS

With regard to the requirements set forth in the following National Standards that are applicable to the ExxonMobil Chemical product referenced above:

- 1) <National Standard of the People's Republic of China GB4806.1-2016, National Food Safety Standard on General Safety Requirements of Food Contact Materials and Articles> (Issue Date: Oct. 19, 2016, Implementation Date: Oct. 19, 2017), and
- 2) <National Standard of the People's Republic of China GB4806.6-2016, National Food Safety Standard on Plastic Resins for Food Contact> (Issue Date: Oct. 19, 2016, Implementation Date: Apr. 19, 2017), and
- 3) <National Standard of the People's Republic of China GB9685-2016, National Food Safety Standard on Use of Additives in Food Contact Materials and Articles> (Issue Date: Oct. 19, 2016, Implementation Date: Oct. 19, 2017), and
- 4) <National Standard of the People's Republic of China GB31603-2015, National Food Safety Standard on General Hygienic Practice for Production of Food Contact Materials and Its Products> (Issue Date: Sep. 21, 2015, Implementation Date: Sep. 21, 2016).

we declare the above product complies with mentioned requirements, and the following information for reference by our downstream customers:

以上埃克森美孚化工产品符合下列国家标准中规定的要求：

- 1) 中华人民共和国国家标准GB4806.1-2016，《食品安全国家标准食品接触材料及制品通用安全要求》（发布日期：2016年10月19日；实施日期：2017年10月19日），及
- 2) 中华人民共和国国家标准GB4806.6-2016，《食品安全国家标准食品接触用塑料树脂》（发布日期：2016年10月19日；实施日期：2017年4月19日），及
- 3) 中华人民共和国国家标准GB9685-2016，《食品安全国家标准食品接触材料及制品用添加剂使用标准》（发布日期：2016年10月19日；实施日期：2017年10月19日）
- 4) 中华人民共和国国家标准GB31603-2015，《食品安全国家标准食品接触材料及制品生产通用卫生规范》（发布日期：2015年9月21日；实施日期：2016年9月21日）

我们提供以下信息供下游客户参考：

#### 1 RESIN

The base resin in the above polymer product is listed in the <National Standard of the People's Republic of China GB4806.6-2016, National Food Safety Standard on Plastic Resins for Food Contact>, and does not contain monomer(s) that is/are subject to a SML or QM restriction.

The n-hexane extractable test was conducted and validated in compliance with < National Standard of the People's Republic of China GB4806.1-2016 National Food Safety Standard on General Safety Requirements of Food Contact Materials and Articles>, < National Standard of the People's Republic of China GB31604.1-2015, National Food Safety Standard on General Rules for Migration Tests for Food Contact Materials and Articles> and the guidance book thereof published in November, 2018, < National Standard of the People's Republic of China GB31604.5-2016, National Food Safety Standard on Food Contact Material and Its Products Determination of Extractive in Resins>. The n-hexane extract level was within the restriction ( 2.00%) under temperature of 50°C.

#### 树脂

上述聚合物产品中的基础树脂列入中华人民共和国国家标准GB4806.6-2016，《食品安全国家标准食品接触用塑料树脂》，该树脂的单体没有特定迁移限量（SML）或最大残留量（QM）的限制。

**Product Name: ExxonMobil™ LDPE LD 653**

**Manufacturing Region: EUROPE**

该基础树脂的正己烷提取物试验根据中华人民共和国国家标准GB4806.1-2016《食品安全国家标准食品接触材料及制品通用安全要求》，中华人民共和国国家标准GB31604.1-2015《食品安全国家标准食品接触材料及制品迁移试验通则》及其2018年11月颁布的实施指南，以及中华人民共和国国家标准GB31604.5-2016《食品安全国家标准食品接触材料及制品树脂中提取物的测定》进行并验证，在试验温度为50 的条件下符合正己烷提取物限量要求( 2.00%)。

## 2 ADDITIVES

The additive(s) (as defined under Article 2.1 of GB9685-2016) that are present in the above product are authorized according to the <National Standard of the People's Republic of China GB9685-2016, National Food Safety Standard on Use of Additives in Food Contact Materials and Articles>.

### 添加剂

上述产品中所含添加剂（根据GB9685-2016第2.1条所定义）根据中华人民共和国国家标准GB9685-2016《食品安全国家标准食品接触材料及制品用添加剂使用标准》允许使用。

The above product does not contain additive(s) that is/are subject to a SML or QM restriction.

上述产品所含添加剂没有特定迁移限量（SML）或最大残留量（QM）的限制。

## GENERAL NOTE:

It is the responsibility of the manufacturer of finished food contact materials and articles - made from or containing this product - to carry out appropriate overall migration limit (OML) and specific migration limit (SML) tests on the finished materials and articles to determine the regulatory suitability for contact with different food-types and various end-use conditions.

We appreciate you choosing our products as part of your raw materials and hope the above information is helpful for your compliance responsibility. If you need further information or have any questions regarding the above or use with other food-types and/or end-uses, please do not hesitate to contact us, we will be happy to provide all relevant information upon your request and, where our proprietary information is involved, under a confidentiality agreement.

### 注：

食品接触材料和制品的制造商有责任对由上述产品制造或含有上述产品的成品材料和制品进行适当的总迁移量（OML）和特定迁移限量（SML）测试，以确定其与不同食品类型接触时符合法规的要求及各种最终使用条件。

感谢您选择我们的产品作为您的原材料的一部分，希望以上信息对您产品合规性判定有所帮助。如果您需要进一步的信息或对以上所述有任何疑问，或对食品类型和/或最终用途有任何疑问，请跟我们联系，我们将很乐意根据您的要求提供所有相关信息。如相关信息需要保密，我们可以在签订保密协议的条件下提供。

## DRINKING WATER STATUS -GER/KTW

With regard to the compliance status of the ExxonMobil Chemical product referenced above with the regulation(s) identified below the following can be declared:

There is currently no harmonized legislation at EU level for materials used in connection with drinking water application. Some EU Member States are currently developing new legal requirements with a view of obtaining a certain harmonization. Therefore, we cannot provide definite statements on the regulatory status of ExxonMobil products with respect to use in drinking water applications.

We recommend you to consult with national laboratories about material and final article requirements.

## EUROPEAN FOOD CONTACT REGULATIONS

With regard to the compliance status of the ExxonMobil Chemical product referenced above with the regulation(s) identified below the following can be declared:

**Product Name: ExxonMobil™ LDPE LD 653**

**Manufacturing Region: EUROPE**

---

## EU FOOD-CONTACT REGULATION

The monomer(s) and the additive(s) intentionally used in the above polymer grade are listed in Annex 1 or are authorized in accordance with the requirements of Commission Regulation (EU) No 10/2011 of 14 January 2011, as amended up to Regulation (EU) No 2020/1245, on plastic materials and articles intended to come into contact with food.

The above polymer grade complies with the relevant requirements of Regulation (EC) No 1935/2004 in as far as:

- \* the grade is produced using Good Manufacturing Practice as required in article 3.1 of Regulation (EC) No 1935/2004 and meets the guidelines for Good Manufacturing Practice as specified in Regulation (EC) No 2023/2006 (on good manufacturing practice for materials and articles intended to come in contact with food).
- \* With respect to Regulation (EC) No 282/2008, no external sources of recycled plastic materials are used for products manufactured according to good manufacturing practice, as laid down in Regulation (EC) No 2023/2006. Regulation (EC) No 282/2008 shall not apply to recycled plastic materials and articles made from unused plastic production offcuts and/or process scraps in compliance with Regulation (EU) No 10/2011 that are recycled within the manufacturing site.
- \* the production of the above grade ensures traceability as required in article 17.1 of Regulation (EC) No 1935/2004.
- \* the polymer production aids and aids to polymerization are either permitted in one or more EU Member State(s) and/or have been risk assessed based on the following assumptions:

100% migration, 1kg/food packed with 6dm<sup>2</sup> of packaging, article thickness of 250 microns

## EU MEMBER STATES

As for the compliance status with EU Member States laws and/or recommendations where specific requirements exist for substances other than monomers and additives, the following can be stated:

The polymer production aids ("PPA")\* and/or aids to polymerization ("AP") possibly present in the above polymer are permitted in the following countries.

\* Solvents are excluded from the "polymerisation production aids" definition.

### Belgium

- "Arrêté royal du 3 juillet 2005 relatif aux matériaux et aux objets en matière plastique destinés à entrer en contact avec les denrées alimentaires", as amended up to "Arrêté royal du 10 février 2011"

### France

- "Arrêté du 2 janvier 2003 relatif aux matériaux et objets en matière plastique mis ou destinés à être mis au contact des denrées, produits et boissons alimentaires", as amended up to "Arrêté du 1er avril 2011"

### Germany

- "Bedarfsgegenständeverordnung in der Fassung der Bekanntmachung vom 23. Dezember 1997 (BGBl. 1998 I S. 5)", as amended up to "Verordnung vom 24.6.2013 (BGBl. I S. 1682)"

- BfR Empfehlung III "Polyethylen" from the Bundesinstitut fuer Risikobewertung "BfR". 01.07.2016

### Italy

- "Decreto 21 marzo 1973, concernente la disciplina igienica degli imballaggi, recipienti, utensili destinati a venire in contatto con le sostanze alimentari o con sostanze d'uso personale", as amended up to "Decreto 04 febbraio 2013, n. 23 (G.U. Serie Generale, n. 71 del 25 marzo 2013)"

### Spain

- "Real Decreto 866/2008, de 23 de mayo, por el que se aprueba la lista de sustancias permitidas para la fabricación de materiales y objetos plásticos destinados a entrar en contacto con los alimentos y se regulan determinadas condiciones de ensayo", as amended up to "Orden PRE/628/2011, de 22 de marzo"

### The Netherlands

- "Warenwetregeling verpakkingen en gebruiksartikelen" Staatscourant kenmerk 328583-117560-VGP from March 14, 2014. Hoofdstuk 1 - Kunststoffen

## SWITZERLAND:

The composition of the above polymer grade meets the requirements of the Swiss Ordinance on material and objects in Plastic, SR 817.023.21 of 16 Dec 2016 (Stand 1. Dezember 2019).

- The composition of the base polymeric component(s) in this polymer grade complies with the positive lists for allowed monomers in the above referenced legislation.
- The additives that may be present comply with the lists for additives in the above referenced legislation, unless explicitly referred to in the additives note below. Information regarding additives subject to a restriction in food (dual use additives) and information on lipophilic substances are not applicable in Switzerland.

**Product Name: ExxonMobil™ LDPE LD 653**

**Manufacturing Region: EUROPE**

---

Monomer restrictions:

None of the monomers used in the production of this polymer is subject to a Specific Migration Limit (SML).

- Presence of additives with SML

None of the additives intentionally used in this polymer grade is subject to a Specific Migration Limit (SML).

- Presence of dual use additives

None of the additives intentionally used in this polymer grade is subject to a restriction in food as referred to in Article 11.3 of Regulation (EU) 10/2011.

Note on Overall Migration Limit ("OML") and on Specific Migration Limits ("SML's"), where applicable

Finished plastics food-contact materials or articles, made from or containing this product, need to comply with Overall Migration Limit ("OML") requirements and Specific Migration Limits ("SML"), where applicable and when tested on the food-contact surface with the appropriate food simulants and time/temperature test conditions. This is the responsibility of the user of this polymer product.

In addition to the above compositional compliance status certification, the polymer user is required to carry out the appropriate overall migration ("OML") and specific migration ("SML") tests on the final material or article to determine the regulatory suitability for contact with different food-types (aqueous, fat/oil, alcoholic, etc.) and various end-use conditions (material or article thickness, pure or in blends, volume, contact time of packaging, temperature of use, etc.), all of which are beyond control of the polymer manufacturer.

## GENERAL NOTE

The manufacturer of food-contact materials and articles - made from or containing this polymer grade - must ensure that the finished materials or articles meet the general regulatory requirements that they do not bring about an unacceptable change in the composition of the foodstuffs or a deterioration in the organoleptic characteristics thereof and do not release constituents in foodstuffs in quantities that can endanger human health.

In addition, the finished food-contact material or article must be technically suitable for the intended use.

## JAPAN FOOD CONTACT REGULATIONS

With regard to the compliance status of the ExxonMobil Chemical product referenced above with the regulation(s) identified below the following can be declared:

Amended Japan Food Sanitation Act (Issue Date: Apr 28, 2020, Implementation date: June 1st, 2020)

The base polymer(s) and the additive(s) intentionally used in the product are listed in the published Positive List (Appendix 1 of the "Standards for the utensils or containers and packaging or the raw materials" under Food Sanitation Act, Article 18, Section 1). The base polymer(s) do not have any food category restriction in the Positive List and do not have maximum temperature of use in the Positive List. The dosage(s) of additive(s) are below the maximum level of use specified in the Positive List for this product.

The manufacturer of food-contact materials and articles made from or containing this product grade must ensure that the finished materials or articles meet the regulatory requirement under the Japan Food Sanitation Act.

## MERCOSUR FOOD CONTACT RESOLUTIONS

With regard to the compliance status of the ExxonMobil Chemical product produced at the Antwerp Polymers Plant referenced above with the resolution(s) identified below the following can be declared:

The above product(s) complies with relevant requirements of Mercosur/GMC/Resolution 3/92 concerning "Guidelines for Food Packaging and Equipment in Contact with Food", as set forth in Annex I.

**Product Name: ExxonMobil™ LDPE LD 653**

**Manufacturing Region: EUROPE**

---

The monomer(s) and other authorized polymers and starting materials intentionally used in the above polymer grade are listed in the Annex or are authorized in accordance with the requirements of Mercosur/GMC/Resolution No. 02/12 for plastic materials intended for the manufacture of food-contact packages and equipment.

The additive(s) intentionally used in the above polymer grade are listed in the Annex or are authorized in accordance with the requirements of Mercosur/GMC/Resolution No. 39/19 for plastic materials intended for the manufacture of food-contact packages and equipment.

The manufacturer of food-contact materials and articles - made from or containing this product grade - must ensure that the finished materials or articles meet the general regulatory requirements and that they do not bring about an unacceptable change in the composition of the foodstuffs or a deterioration in the organoleptic characteristics thereof and do not release constituents in foodstuffs in quantities that can endanger human health.

Furthermore, the manufacturer of food-contact materials and articles that contain this product as a component must also ascertain that the finished materials or articles meet any migration limits, composition requirements and/or other restrictions in use that may be applicable for the specific finished material or article and for its specific intended use in some or all countries.

In addition, the finished food-contact material or article must be technically suitable for the intended use.

## **UNITED STATES FOOD REGULATIONS DIRECT FOOD ADDITIVE (FDA)**

Direct food additive claims and/or Secondary Direct food additive (with a technical effect) claims are currently not available for the product grade above.

## **UNITED STATES FOOD REGULATIONS INDIRECT FOOD ADDITIVE (FDA)**

With regard to the compliance status of the ExxonMobil Chemical product referenced above with the regulation(s) identified below the following can be declared:

This product complies with FDA regulation 21 CFR 177.1520 (Olefin polymers), paragraphs (c)2.1 and (c)2.2, and may be used as articles or components of articles intended for use in contact with food, including use in articles used for packing or holding food during cooking.

This product is produced under conditions of good manufacturing practice as required by 21 C.F.R. § 174.5(a) and is of a purity suitable for its intended use in food contact applications in accordance with the regulatory citations identified above.

The manufacturer of an indirect food additive, food contact substance, or article containing this product has the responsibility to ensure compliance with all applicable FDA laws and regulations to ensure that any finished food contact article is of a purity suitable for its intended use.

**Product Name: ExxonMobil™ LDPE LD 653**

**Manufacturing Region: EUROPE**

---

## Category: Other Regulations

### ALLERGENS IN FOOD

With regard to the compliance status of the ExxonMobil Chemical product referenced above with the regulation(s) identified below the following can be declared:

With regards to the presence of food allergens:

EUROPE:

The following substances or products causing allergies or intolerances (as listed in annex II of regulation (EU) No 1169/2011 on the provision of food information to consumers), amended up to REGULATION (EU) 2015/2283 OF THE EUROPEAN PARLIAMENT AND OF THE COUNCIL:

1. Cereals containing gluten, namely: wheat (such as spelt and khorasan wheat), rye, barley, oats or their hybridised strains, and products thereof; 2. Crustaceans and products thereof; 3. Eggs and products thereof; 4. Fish and products thereof; 5. Peanuts and products thereof; 6. Soybeans and products thereof; 7. Milk and products thereof (including lactose); 8. Nuts, namely: almonds (*Amygdalus communis* L.), hazelnuts (*Corylus avellana*), walnuts (*Juglans regia*), cashews (*Anacardium occidentale*), pecan nuts (*Carya illinoensis* (Wangenh.) K. Koch), Brazil nuts (*Bertholletia excelsa*), pistachio nuts (*Pistacia vera*), macadamia or Queensland nuts (*Macadamia ternifolia*), and products thereof, except for nuts used for making alcoholic distillates including ethyl alcohol of agricultural origin; 9. Celery and products thereof; 10. Mustard and products thereof; 11. Sesame seeds and products thereof; 12. Sulphur dioxide and sulphites at concentrations of more than 10 mg/kg or 10 mg/litre in terms of the total SO<sub>2</sub> which are to be calculated for products as proposed ready for consumption or as reconstituted according to the instructions of the manufacturers; 13. Lupin and products thereof; 14. Molluscs and products thereof. are not intentionally used by ExxonMobil in this product.

USA:

The following food allergens (as referred to in the Allergen Labeling and Consumer Protection Act of 2004. 21 note- FALCPA)

(1) Milk, egg, fish (e.g., bass, flounder, or cod), crustacean shellfish (e.g., crab, lobster, or shrimp), tree nuts (e.g., almonds, pecans, or walnuts), wheat containing gluten-, peanuts, and soybeans. (2) Food ingredient that contains protein derived from a food specified in paragraph above are not intentionally used by ExxonMobil in this product.

Canada:

As in effect 4 August 2012, food allergen means any protein from any of the following foods, or any modified protein that includes any protein fraction derived from any of the following foods: [B.01.010.1(1), FDR].

- almonds, Brazil nuts, cashews, hazelnuts, macadamia nuts, pecans, pine nuts, pistachios or walnuts;
- peanuts;
- sesame seeds;
- wheat or triticale;
- eggs;
- milk;
- soybeans;
- crustaceans
- shellfish;
- fish; or
- mustard seeds;
- gluten protein, modified gluten protein, or gluten protein fractions from barley, oats, rye, triticale or wheat (or a hybridized strain of any of these cereals) are not intentionally used by ExxonMobil in this product.

Although this product is not routinely tested for their presence, based on product composition knowledge these substances are not expected to be present. However, the fact that these substances are not intentionally used by ExxonMobil in this product does not exclude that trace levels of these substances may be present as a result of the specific characteristics of the raw materials and/or of the manufacturing process.

### ANIMAL DERIVED SUBSTANCES

We are pleased to provide the following information concerning the absence or presence of certain substances in the ExxonMobil Chemical product referenced above:

Substances of animal origin are not intentionally used by ExxonMobil in this product. Although this product is not routinely tested for their presence, based on product composition knowledge these substances are not expected to be present. However, the fact that these substances are not intentionally used by ExxonMobil in this product does not exclude that trace levels of these substances may be present as a result of the specific characteristics of the raw materials and/or of the manufacturing process.

**Product Name: ExxonMobil™ LDPE LD 653**

**Manufacturing Region: EUROPE**

---

## **BADGE- NOGE - EU 1895/2005**

With regard to the compliance status of the ExxonMobil Chemical product referenced above with the regulation(s) identified below the following can be declared:

This product complies with the Commission Regulation 1895/2005 on "the restriction of use of certain epoxy derivatives in materials and articles intended to come into contact with food".

The following substances,

- 2,2-bis(4-hydroxyphenyl)propane bis(2,3-epoxypropyl) ether (BADGE),
- Bis(hydroxyphenyl)methane bis(2,3-epoxypropyl)ethers (BFDGE), and
- Novolac glycidyl ethers (NOGE),

and their derivatives, are not intentionally used by ExxonMobil in this product. Although this product is not routinely tested for their presence, based on product composition knowledge these substances are not expected to be present. However, the fact that these substances are not intentionally used by ExxonMobil in this product does not exclude that trace levels of these substances may be present as a result of the specific characteristics of the raw materials and/or of the manufacturing process.

## **CALIFORNIA PROP 65 - POLYMERS**

With regard to the compliance status of the ExxonMobil Chemical product referenced above with the regulation(s) identified below the following can be declared:

Although this product is not routinely tested for Proposition 65 listed substances, based on product composition knowledge these substances are not expected to be present. However, the fact that these substances are not intentionally used by ExxonMobil Chemical in this product does not exclude that trace levels may be present as a result of the specific characteristics of the raw materials and/or the manufacturing process.

## **CANADIAN EPA**

We are pleased to provide the following information concerning the absence or presence of certain substances in the ExxonMobil Chemical product referenced above:

The List of Toxic Substances in Schedule 1 of the Canadian Environmental Protection Act, 1999 (CEPA 1999) includes substances that are considered to be toxic as defined in Section 64 of the Act.

Although substances in the List of Toxic Substances in Schedule 1 are not intentionally used as a functional component in the final product, there is some indication that trace levels of the substances in the List of Toxic Substances in Schedule 1 may be present as a result of the specific characteristics of the raw materials and/or of the manufacturing process.

## **CLASSIFICATION & LABELING INFORMATION**

With regard to the compliance status of the ExxonMobil Chemical product referenced above with the regulation(s) identified below the following can be declared:

Classification and labeling information according to latest legislation requirements can be found in the ExxonMobil Chemical Safety Data Sheets for relevant product / country combinations. ExxonMobil Chemical SDS's are available on internet:

[msds.exxonmobil.com](https://msds.exxonmobil.com)

## **CONEG/WASTE PACKAGING**

With regard to the compliance status of the ExxonMobil Chemical product referenced above with the regulation(s) identified below the following can be declared:

This product is in compliance with the relevant heavy metals requirements of the following regulations:

- European Parliament and Council Directive 94/62/EC of 20 December 1994 on packaging and packaging waste ("Packaging and Packaging Waste Directive"), as amended up to Commission Directive 2018/852 of 30 May 2018.
- CONEG (Coalition of Northeastern Governors) Model Legislation.

The sum of the concentrations of the following heavy metals,

- mercury, lead, cadmium and hexavalent chromium, in this product does not exceed 100 parts per million by weight.

**Product Name: ExxonMobil™ LDPE LD 653**

**Manufacturing Region: EUROPE**

---

Trace levels of these substances may be present as a result of the specific characteristics of the raw materials and/or of the manufacturing process.

## **COSMETICS / INCI**

With regard to the compliance status of the ExxonMobil Chemical product referenced above with the regulation(s) identified below the following can be declared:

Regulation (EC) No 1223/2009 of the European Parliament and of the Council of 30 November 2009 on cosmetic products, applies to cosmetics products and their ingredients as defined by the Article 1 of this regulation (\*).

The above polymer grade is not intended to be used as ingredient of cosmetics or as cosmetic product.

However, following information should be considered :

\* EU Safety Data Sheet according to Regulation (EC) No 1907/2006 requirements.

\* Product Regulatory Summary document, including but not limited to following paragraphs: Presence / Absence, EUROPEAN FOOD CONTACT REGULATIONS, REACH CANDIDATE LIST, REACH-1907/2006 ANNEX XVII, CALIFORNIA PROP 65.

\* Above polymer grade does not contain intentionally used substances listed in in Annex II or III of the Cosmetics Regulation 1223/2009, as amended up to Regulation 2019/1966, which are present at levels above 10 ppm or migrating in levels above 100 ppb from final packaging article and not reported in above mentioned information.

Although this product is not routinely tested for their presence, based on product composition knowledge, these substances are not expected to be present. However, the fact that these substances are not intentionally used by ExxonMobil in this product does not exclude that trace levels of these substances may be present as a result of the specific characteristics of the raw materials and/or of the manufacturing process.

(\*) A 'cosmetic product' means any substance or mixture intended to be placed in contact with the external parts of the human body (epidermis, hair system, nails, lips and external genital organs) or with the teeth and the mucous membranes of the oral cavity with a view exclusively or mainly to cleaning them, perfuming them, changing their appearance, protecting them, keeping them in good condition or correcting body odours.

## **DIMETHYLFUMARATE**

With regard to the compliance status of the ExxonMobil Chemical product referenced above with the regulation(s) identified below the following can be declared:

Dimethylfumarate (DMF) CAS No 624-49-7 is not intentionally used by ExxonMobil in this product. Although this product is not routinely tested for its presence, based on product composition knowledge this substance is not expected to be present. However, the fact that this substance is not intentionally used by ExxonMobil in this product does not exclude that trace levels of this substance may be present as a result of the specific characteristics of the raw materials and/or of the manufacturing process.

## **DRUG MASTER FILE (US FDA)**

With regard to the compliance status of the ExxonMobil Chemical product referenced above with the regulation(s) identified below the following can be declared:

This product is not included in a U. S. FDA Drug Master File (DMF).

## **END OF LIFE VEHICLE - EU**

With regard to the compliance status of the ExxonMobil Chemical product referenced above with the regulation(s) identified below the following can be declared:

This product is in compliance with the relevant heavy metal requirements of the following regulation:

- EU 2000/53/EC Directive (Article 4) on end-of life vehicles amended up to
- Commission Directive (EU) 2018/849 of 30 May 2018.

The concentrations of the following heavy metals,

- lead, cadmium, mercury & hexavalent chromium,

do not exceed

**Product Name: ExxonMobil™ LDPE LD 653**

**Manufacturing Region: EUROPE**

---

- 0.1 percent by weight for lead, mercury, & hexavalent chromium, and
- 0.01 percent by weight for cadmium.

Trace levels of these substances may be present resulting from the specific characteristics of the raw materials and/or of the manufacturing process.

As far as hazardous substances are concerned (Article 4 - "Prevention" of Directive 2000/53/EC), we can confirm that this product is classified as non-dangerous according to the requirements of the Regulation (EC) No 1907/2006, as amended.

Details on the possible presence in this product of substances classified as dangerous under Regulation (EC) No 1907/2006, as amended, can be found in Section 3 of the Safety Data Sheet (SDS), provided the concentration of such substances exceeds the concentration threshold for disclosure as stipulated in the Guide to the Compilation of Safety Data Sheets (Annex II of Regulation 1907/2006).

## ENDOCRINE DISRUPTORS

We are pleased to provide the following information concerning the absence or presence of certain substances in the ExxonMobil Chemical product referenced above:

There is currently no authoritative or regulatory list of endocrine disruptors. Therefore, we cannot provide definitive statements regarding their presence or absence in our products at this time. You can contact your ExxonMobil Customer Service Professional about specific substances of concern.

## EU BIOCIDES

We are pleased to provide the following information concerning the absence or presence of certain substances in the ExxonMobil Chemical product referenced above:

The above product has not been registered by ExxonMobil Chemical as a biocidal product, as defined in the Biocidal Products Regulation (BPR – 528/2012). ExxonMobil is not intentionally using as active substance in this product, the substances as listed in:

- Annex 1 "List of active substances referred to in Article 25" of Regulation (EU) No 528/2012 of the European Parliament and of the Council
- the Union list of approved active substances referred to in article 9.2 of Regulation (EU) No 528/2012 of the European Parliament and of the Council. (Last review : Commission implementing Regulation (EU) 2018/1622 of 30 October 2018).

Although this product is not routinely tested for their presence, based on product composition knowledge, these substances are not expected to be present.

## EURASIA AND RUSSIA REACH

Eurasian Economic Union Technical Regulation (TR 041/2017) and Russian Technical Regulation (TR 1019/2016) Communication

The information below is related to the TR 1019/2016 on Safety of Chemical Products (so-called "Russian REACH") and Eurasian Economic Union Technical Regulation 041/2017 on Safety of Chemical Products (so-called "Eurasia REACH"). The Eurasian Economic Union (EEU) covers the Republic of Armenia, Republic of Belarus, Republic of Kazakhstan, Kyrgyz Republic, and Russian Federation.

### 1. TR 1019/2016 on Safety of Chemical Products

Russia officially revoked its Technical Regulation on Safety of Chemical Products (1019/2016), according to a Government Decree issued on 14 June 2019. By revoking the Russian Regulation, Decree No. 761 eliminates a possible conflict or confusion with the EEU Technical Regulation on Safety of Chemical Products (041/2017).

Manufacturers/importers can now ignore the revoked Russian Regulation and focus on the implementation of the EEU TR 041/2017 on Safety of Chemical Products.

### 2. EEU Technical Regulation 041/2017 On Safety of Chemical Products

#### 2.1 Chemical Inventory - The Register Formation

In support of the implementation of the EEU Technical Regulation, Russia created its portion of the EEU Register of Chemical substances and mixtures and appointed the Coordination information centre to complete the task. Manufacturers/importers have been encouraged to complete internal inventories of chemicals placed or to be placed on the Russian market and submit the relevant information to the GISP portal. After careful evaluation, ExxonMobil has submitted information to the Russian Authorities about all substances (including substances in mixtures), that we manufacture or import into the EEU by the end of 2019.

2.2 State Registration Procedure With regards to the EEU state registration procedure, at this time, ExxonMobil intends to ensure registration of all relevant

**Product Name: ExxonMobil™ LDPE LD 653**

**Manufacturing Region: EUROPE**

in-scope substances which we supply to the EEU. However, a range of factors could influence our final decision on whether to register certain individual substances and ExxonMobil will consider all available options. This will take some time to evaluate as we progress through the registration process. Since the registration time frame is set until the end of 2033 and may possibly be extended, it is not, at this point in time, possible to provide firm statements about the exact details of substances and mixtures to be registered and continued product availability. Any EEU-based importer will also have the obligation to fulfil the EEU TR 041/2017 registration obligations. To relieve importers of their obligation to register, ExxonMobil may arrange Only Representative support. Please contact your usual ExxonMobil representative for more information. Meanwhile, we can confirm that there are currently no plans to reformulate or discontinue any products supplied to you for the EEU market, and we do not anticipate this situation changing in the foreseeable future. In case of any changes in ExxonMobil's portfolio availability, we will work with customers to ensure a smooth transition to alternatives, if needed. We remain at your disposal for any further question or clarification you may need. ExxonMobil strongly recommends that customers specifically assess their legal responsibilities under EEU TR 041/2017 on Safety of Chemical Products when importing into the Eurasia Economic Area. Companies based outside of the Eurasia Economic Union, who intend to export ExxonMobil products purchased outside of the Eurasia Economic Union should consider the technical regulations obligations, including but not limited to EEU TR 041/2017 on Safety of Chemical Products registration.

## HALAL STATUS

We are pleased to provide the following Product Stewardship information for the ExxonMobil Chemical product referenced above.

This product is not halal certified.

However, substances of animal origin and ethanol are not intentionally used by ExxonMobil in this product. Although this product is not routinely tested for their presence, based on product composition knowledge these substances are not expected to be present. However, the fact that these substances are not intentionally used by ExxonMobil in this product does not exclude that trace levels of these substances may be present as a result of the specific characteristics of the raw materials and/or of the manufacturing process.

## HAZARDOUS AIR POLLUTANTS-HAPS

With regard to the compliance status of the ExxonMobil Chemical product referenced above with the regulation(s) identified below the following can be declared:

The federal Clean Air Act Amendments of 1990 (CAAA) established a federal operating permit program under the Title V of the Act. This program applies to all sources of air pollutants and is administered at the state level. One category of pollutants covered by Title V is Hazardous Air Pollutants (HAPs). This product is a polymer which is not a HAP as defined in the subject regulation. However, it may contain some residual volatile compounds, such as monomer and solvent residues, that are included on the HAPs list. The HAPs concentration in this product would typically stay below 1 wt%.

Degradation products ("fumes"), potentially including formaldehyde, can be formed during high temperature processing of this product.

## IMDS STATUS

We are pleased to provide the following information concerning the description into IMDS of the ExxonMobil Chemical product referenced above:

According to the IMDS recommendations for the creation of Material Data Sheets (MDS), and according to GADSL list used as reference

- the ExxonMobil products are grouped by families,
- these families are entered into IMDS as "Materials", that consist of basic substances only,
- a family is identified by a generic "Trade name" but more importantly by an "ID",
- data are "published" without restriction which means they can be consulted by any company having an authorized IMDS access,

The ExxonMobil Chemical product referenced above is described by the

IMDS Material Data Sheet of ID 9706856.

## JATROPHA PLANT DERIVATIVES

We are pleased to provide the following information concerning the absence or presence of certain substances in the ExxonMobil Chemical product referenced above.

Substances of Jatropha plant origin, including oils, and glycerin and protein co-products are not intentionally used by ExxonMobil Chemical in this product. Although this product is not tested for their presence, based on product composition knowledge and information obtained from surveying our suppliers, these substances are not expected to be present.

**Product Name: ExxonMobil™ LDPE LD 653**

**Manufacturing Region: EUROPE**

---

On July 6, 2012, the U.S. Food and Drug Administration (FDA) issued a FDA Notification to Industry on the Jatropha plant issue. At that time, the FDA was unaware of any intentional substitution or contamination in FDA-regulated finished products or components derived from the Jatropha plant. The FDA is monitoring the situation to assess impacts on FDA-regulated products and is working to develop test methods for the Jatropha-based ingredients.

In April 2014, the FDA issued an updated statement with the following Fast Facts: • Industry should continue to be vigilant in preventing the use of Jatropha-derived ingredients in FDA-regulated products. • A recent supply chain study for Malaysia and Indonesia showed that Jatropha production appears to be minimal, though this finding might not hold for other regions. • FDA has no evidence that Jatropha-derived ingredients have entered U.S. food and drug supply chains to date.

## **KOSHER STATUS**

We are pleased to provide the following Product Stewardship information for the ExxonMobil Chemical product referenced above:

This product is not kosher certified.

## **MINERAL OIL**

We are pleased to provide the following information concerning the absence or presence of certain substances in the ExxonMobil Chemical product referenced above.

Although Mineral Oil is not intentionally added by ExxonMobil nor is this product routinely tested for its presence, there is some indication that Mineral Oil may be present as a result of the specific characteristics of the raw materials and/or of the manufacturing process. The constituents of the Mineral Oil are primarily saturated hydrocarbons.

## **NANO-SCALE MATERIALS**

We are pleased to provide the following information concerning the absence or presence of certain substances in the ExxonMobil Chemical product referenced above:

There is currently no consensus regulatory definition for nano-materials. However, this product does not contain engineered nano-scale materials with one or more dimensions less than 100nm.

Although this product is not routinely tested for the presence of nano-scale materials, based on product composition knowledge these substances are not expected to be present. However, the fact that these substances are not intentionally used by ExxonMobil in this product does not exclude that trace levels of these substances may be present as a result of the specific characteristics of the raw materials and/or of the manufacturing process.

## **NATIONAL CHEMICAL INVENTORY**

With regard to the compliance status of the ExxonMobil Chemical product referenced above with the regulation(s) identified below the following can be declared:

The base polymer of this product is an "Ethylene Homopolymer" with CAS number 9002-88-4.

United States of America: This product meets the regulatory requirements pursuant to the United States Toxic Substances Control Act (TSCA) Inventory. This product is on the active inventory.

Canada: This product meets the regulatory requirements pursuant to the Canadian Domestic Substances List (DSL).

Australia: This product meets the regulatory requirements pursuant to the Australian Inventory of Chemical Substances (AICS).

Japan: This product meets the regulatory requirements pursuant to the Japanese inventory of Existing and New Chemical Substances (ENCS).

Korea: This product meets the regulatory requirements pursuant to the Korean Existing Chemicals List (KECI).

**Product Name: ExxonMobil™ LDPE LD 653**

**Manufacturing Region: EUROPE**

---

China: This product meets the regulatory requirements pursuant to the China Inventory of Existing Chemical Substances (IECSC).

Philippines: This product meets the regulatory requirements pursuant to the Philippines Inventory of Chemicals and Chemical Substances (PICCS).

New Zealand: This product meets the regulatory requirements pursuant to the New Zealand Inventory of Chemicals (NZIoC).

Taiwan: This product meets the regulatory requirements pursuant to the Taiwan Chemical Substance Inventory (TCSI).

## OZONE DEPLETING SUBSTANCES

With regard to the compliance status of the ExxonMobil Chemical product referenced above with the regulation(s) identified below the following can be declared:

Ozone depleting substances, as set forth in

- Appendices A (Class I) and B (Class II) of 40 CFR Part 82 Subpart A,
- REGULATION (EC) No 1005/2009 of the EUROPEAN PARLIAMENT and of the COUNCIL on substances that deplete the ozone layer, last amended by COMMISSION REGULATION (EU)2017/605 of 29 March 2017 amending Annex VI and
- Montreal Protocol and amendments - Annexes A, B, C, & E,

are not intentionally used by ExxonMobil in this product. Although this product is not routinely tested for their presence, based on product composition knowledge these substances are not expected to be present. However, the fact that these substances are not intentionally used by ExxonMobil in this product does not exclude that trace levels of these substances may be present as a result of the specific characteristics of the raw materials and/or of the manufacturing process.

## PERSISTENT ORGANIC POLLUTANTS

We are pleased to provide the following information concerning the absence or presence of certain substances in the ExxonMobil Chemical product referenced above.

Persistent Organic Pollutants (as listed in the Stockholm Convention - last amended May 2019) are not intentionally used by ExxonMobil in this product. Although this product is not routinely tested for their presence, based on product composition knowledge these substances are not expected to be present. However, the fact that these substances are not intentionally used by ExxonMobil in this product does not exclude that trace levels of these substances may be present as a result of the specific characteristics of the raw materials and/or of the manufacturing process.

## PESTICIDES

We are pleased to provide the following information concerning the absence or presence of certain substances in the ExxonMobil Chemical product referenced above.

The above product is a polymer not intended for use as a pesticide.

The above product is not listed in the Annex "Active Substances Approved For Use In Plant Protection Products (i.e. fungicides, insecticides, plant growth regulators, rooting hormones, preserving plant products, herbicides, weed killers ...) of the Commission Regulation No 540/2011 implementing Regulation (EC) No 1107/2009 as regards the list of approved active substances - Amendments - Commission implementing Regulation (EU) 2018/1915 of 6 December 2018

and

- the U.S.EPA/OPP's PPIS databases (pesticide and ingredients) available from the NPIRS National Pesticide Information Retrieval System.

## PHARMACOPOEIA STATUS (EU)

With regard to the compliance status of the ExxonMobil Chemical product referenced above with the regulation(s) identified below the following can be declared:

This product is not intended for or supported by ExxonMobil Chemical for use in pharmaceutical or medical applications requiring compliance with European Pharmacopoeia.

**Product Name: ExxonMobil™ LDPE LD 653**

**Manufacturing Region: EUROPE**

---

## PHARMAPOEIA STATUS (US)

With regard to the compliance status of the ExxonMobil Chemical product referenced above with the regulation(s) identified below the following can be declared:

This product is not intended for or supported by ExxonMobil Chemical for use in pharmaceutical or medical applications requiring compliance with U.S. Pharmacopoeia.

## PNA / PAH

We are pleased to provide the following information concerning the absence or presence of certain substances in the ExxonMobil Chemical product referenced above:

Polynuclear aromatic hydrocarbons (PNAs/PAHs) are not intentionally used by ExxonMobil in this product. Although this product is not routinely tested for their presence, based on product composition knowledge these substances are not expected to be present. However, the fact that these substances are not intentionally used by ExxonMobil in this product does not exclude that trace levels of these substances may be present as a result of the specific characteristics of the raw materials and/or of the manufacturing process.

Examples of PNAs/PAHs include, but are not limited to:

- Benz(a)anthracene,
- Benzo(a)pyrene,
- Benzo(b)fluoranthene,
- Benzo(e)pyrene,
- Benzo(g,h,i)perylene,
- Dibenz(a,h)anthracene,
- Chrysene,
- Indeno(1,2,3-cd)pyrene, - Pyrene, and - Anthracene

## REACH CANDIDATE LIST

With regard to the compliance of the ExxonMobil Chemical product referenced above with the regulation(s) identified below, the following can be declared:

On January 19th, 2021 the European Chemicals Agency (ECHA) added 2 new substances to the Candidate list of Substances for eventual inclusion on the Annex XIV List of Substances subject to Authorisation on its website. This brings the total number of Substances of Very High Concern (SVHC) on the Candidate List to 211.

Following ECHA's publication of the inclusion of an SVHC in the Candidate List according to Article 59(1) of REACH, additional information requirements may apply. They are based on the Article 31 (Safety Data Sheets) and on the Article 33 (Substances in articles) of REACH.

According to our records, the above ExxonMobil product when supplied by ExxonMobil in EU Member States and EEA countries DOES NOT contain a Candidate List substance that triggers an additional action.

Any candidate list substance identified as being present in ExxonMobil products will be identified in the relevant sections of the EU Safety Data Sheet. The above ExxonMobil product does not contain candidate list substances at levels triggering obligations under REACH Article 31.

Based upon the above and the information currently available, we have no evidence that the above product supplied by ExxonMobil within the EU Member States and EEA countries contains any of the substances identified on the Candidate List at levels which would require action under REACH Articles 31 or 33.

The information contained above is provided in good faith. No representations or warranties are made as to its completeness or accuracy. ExxonMobil will not be liable for any damages resulting from the use of or reliance on the information.

## REACH REG - OR

As part of ExxonMobil's REACH communication plans, a website has been developed to assist customers in finding answers to most typical REACH-related questions including but not limited to registration status, Substances of Very High Concern (SVHC), uses, ... etc. Link to the ExxonMobil REACH web:

<https://www.exxonmobil.eu/en-eu/exxonmobil-in-europe/reporting/reach>

The information refers only to ExxonMobil products which are purchased by customers directly from an ExxonMobil affiliate in the European Economic Area. ExxonMobil products imported into the European Economic Area by customers either directly or as part of a mixture are not covered by this data or information. Companies based outside of EU/EEA(\*), who intend to export ExxonMobil products purchased outside EU/EEA (\*) should consider the REACH obligations including but not limited to REACH registrations.

A non-EU manufacturer can choose to appoint an Only Representative to relieve importers of the obligation to register. ExxonMobil does not

**Product Name: ExxonMobil™ LDPE LD 653**

**Manufacturing Region: EUROPE**

---

routinely provide such service for this product. For more information about Only Representative support, please contact your normal ExxonMobil sales rep.

ExxonMobil continues to strongly recommend that customers should specifically assess their legal responsibilities under REACH when importing into the European Economic Area.

## REACH-1907/2006 ANNEX XVII

With reference to Annex XVII of REACH Regulation (EC) No 1907/2006, "Restrictions on the manufacturing, Placing on the Market and Use of Certain Dangerous Substances, Preparations and Articles", with amendments published on ECHA web up to September 18, 2019 the following can be declared:

This product is or do not contain substances identified in Annex XVII in reportable quantities. ExxonMobil expressly disclaims any and all liability of direct, indirect or consequential nature for any loss, damage, or injury suffered or incurred, directly and indirectly, as to any results obtained or arising from any use of the substance in reliance on this technical information, unless this information is directly based upon gross negligence, willful misconduct or - in case of bodily injury - simple negligence of ExxonMobil.

## ROHS

With regard to the compliance status of the ExxonMobil Chemical product referenced above with the regulation(s) identified below the following can be declared:

This product is in compliance with the relevant heavy metals, flame retardants and phthalates requirements of the following regulation:

Directive 2011/65/EU of the European Parliament and of the Council of 8 June 2011 on the restriction of the use of certain hazardous substances in electrical and electronic equipment (EEE), RoHS II – amended by Directive (EU) 2017/2102 of the European Parliament and of the Council of 15 November 2017 and including amendment of Annex II for restricted substances up to Commission delegated Directive (EU) 2015/863 of 31 March 2015 and amendments of Annex III and IV for exemptions up to Directive (EU) 2019/1846 of 5 November 2019.

The concentrations of the following heavy metals (lead, cadmium, mercury & hexavalent chromium) flame retardants [polybrominated biphenyls (PBBs), polybrominated diphenyl ethers (PBDEs)] the following phthalates [Bis(2-Ethylhexyl) phthalate (DEHP), Benzyl butyl phthalate (BBP), Dibutyl phthalate (DBP), Diisobutyl phthalate (DIBP)]

in this product do not exceed 0.1% by weight for lead, mercury, hexavalent chromium, PBBs, PBDEs & phthalates and 0.01% by weight for cadmium. Traces levels of these substances may be present resulting from the specific characteristics of the raw materials and/or of the manufacturing process.

## SAFETY OF TOYS

With regard to the compliance status of the ExxonMobil Chemical product referenced above with the regulation(s) identified below the following can be declared:

Directive 2009/48/EC of 18 June 2009 on the safety of toys, as amended up to Commission directive (EU) 2019/1922 of 19 November 2019, includes safety requirements the toys need to comply with in order to be placed on the market.

As for compliance of the above product with the requirements set out in Annex II "Particular Safety requirements" - Paragraph III - of the Directive, the following can be declared:

- This polymer is a preparation that is not classified according to the criteria set out in Annex I of Regulation 1272/2008.
- Allergenic fragrances, as listed in Annex II.III.11 are not intentionally used in this polymer.
- Nitrosamines and nitrosable substances are not intentionally used in this polymer.
- The following metallic elements, referred to in the European Norm EN 71-3:2013 (Safety of toys - Part 3: Migration of certain elements) are not intentionally used in this polymer. Although this product is not routinely tested for their presence, based on product composition knowledge these metallic elements are not expected to be present.

Aluminium, Antimony, Arsenic, Barium, Boron, Cadmium, Chromium (III), Chromium (VI), Cobalt, Copper, Lead, Manganese, Mercury, Nickel, Selenium, Strontium, Tin, Organic tin, Zinc

As regards the European Norm EN 71-9:2005+A1:2007 ("Safety of Toys - Part 9: Organic Chemical Compounds - Requirements"), the requirements established by the European Commission for the substances listed in the following "Limit tables" address the risks presented by

**Product Name: ExxonMobil™ LDPE LD 653**

**Manufacturing Region: EUROPE**

---

organic compounds in polymeric toy materials used in toys and toy components:

- Table 2B - Colourants
- Table 2C - Primary aromatic amines
- Table 2D - Monomers (migration) (See note 1)
- Table 2E - Solvents (migration)
- Table 2F - Solvents (inhalation)
- Table 2H - Preservatives (other than wood preservatives) (See note 1)
- Table 2I - Plasticizers (migration)

These substances are not intentionally used by ExxonMobil in this product. Although this product is not routinely tested for their presence, based on product composition knowledge these substances are not expected to be present. However, the fact that these substances are not intentionally used by ExxonMobil in this product does not exclude that trace levels of this substance may be present as a result of the specific characteristics of the raw materials and/or of the manufacturing process.

Note 1: Degradation products ("fumes"), potentially including formaldehyde can be formed during high temperature processing of the above polymer.

Note 2: It remains the specific responsibility of the user of this polymer product to check and assure that the finished toys, made from or containing this polymer product as a component, do not present health hazards or risks of physical injury by ingestion, inhalation or contact with the skin, mucous tissues or eyes. These effects may be due to various reasons, such as addition of other substances (colorants, masterbatches, waxes, mould release agents, etc.), decomposition during conversion at high temperatures, hypersensitivity during the intended conditions of use of the toys to any of the components or substances present in the finished article.

Note 3: The document EN 71-9 gives requirements for organic compounds in certain toys and toy materials. The EN 71-9 document should be read in conjunction with part EN 71-10, which describes sample preparation and extraction procedures, and part EN 71-11 which specifies methods of analysis.

## **TSCA 12B STATUS**

With regard to the compliance status of the ExxonMobil Chemical product referenced above with the regulation(s) identified below the following can be declared:

This product does not contain any substances on the TSCA Section 12(b) export notification list above de minimus levels.

## **VOLATILE ORGANIC CPDS-VOC -EU**

We are pleased to provide the following information concerning the absence or presence of certain substances in the ExxonMobil Chemical product referenced above:

This polymer is not a Volatile Organic Compound (VOC) according to Directive 2010/75/EU of the European Parliament and the Council on industrial emissions (IE). However, it may contain some residual volatile compounds such as monomer and solvent residues. The VOC concentration of this product would typically stay below 3 weight %.

## **VOLATILE ORGANIC CPDS-VOC -USA**

We are pleased to provide the following information concerning the absence or presence of certain substances in the ExxonMobil Chemical product referenced above:

This polymer is not a Volatile Organic Compound (VOC) as defined by the U.S. Environmental Protection Agency (U.S. EPA). However, it may contain some residual compounds such as monomer and solvent residues; the concentration of these compounds is typically below 0.1 weight %.

**Product Name: ExxonMobil™ LDPE LD 653**

**Manufacturing Region: EUROPE**

---

## Category: Presence / Absence

### 2-ETHYL-1-HEXANOL

We are pleased to provide the following information concerning the absence or presence of certain substances in the ExxonMobil Chemical product referenced above.

2-Ethyl-1-hexanol (CAS no. 104-76-7) is not intentionally used by ExxonMobil in this product. Although this product is not routinely tested for its presence, based on product composition knowledge this substance is not expected to be present. However, the fact that this substance is not intentionally used by ExxonMobil in this product does not exclude that trace levels of this substance may be present as a result of the specific characteristics of the raw materials and/or of the manufacturing process.

### ACRYLAMIDE

We are pleased to provide the following information concerning the absence or presence of certain substances in the ExxonMobil Chemical product referenced above:

Acrylamide (CAS no. 79-06-1) is not intentionally used by ExxonMobil in this product. Although this product is not routinely tested for its presence, based on product composition knowledge this substance is not expected to be present. However, the fact that this substance is not intentionally used by ExxonMobil in this product does not exclude that trace levels of this substance may be present as a result of the specific characteristics of the raw materials and/or of the manufacturing process.

### ACRYLONITRILE

We are pleased to provide the following information concerning the absence or presence of certain substances in the ExxonMobil Chemical product referenced above:

Acrylonitrile (CAS no. 107-13-1) is not intentionally used by ExxonMobil in this product. Although this product is not routinely tested for its presence, based on product composition knowledge this substance is not expected to be present. However, the fact that this substance is not intentionally used by ExxonMobil in this product does not exclude that trace levels of this substance may be present as a result of the specific characteristics of the raw materials and/or of the manufacturing process.

### ALKYL MESILATES

We are pleased to provide the following information concerning the absence or presence of certain substances in the ExxonMobil Chemical product referenced above:

Alkyl mesilates, e.g., methane sulphonic acid methyl esters (MMS) and methane sulphonic acid ethyl esters (EMS) are not intentionally used by ExxonMobil in this product. Although this product is not routinely tested for their presence, based on product composition knowledge these substances are not expected to be present. However, the fact that these substances are not intentionally used by ExxonMobil in this product does not exclude that trace levels of these substances may be present as a result of the specific characteristics of the raw materials and/or of the manufacturing process.

### ASBESTOS

We are pleased to provide the following information concerning the absence or presence of certain substances in the ExxonMobil Chemical product referenced above:

Asbestos (CAS no. 1332-21-4) is not intentionally used by ExxonMobil in this product. Although this product is not routinely tested for its presence, based on product composition knowledge this substance is not expected to be present. However, the fact that this substance is not intentionally used by ExxonMobil in this product does not exclude that trace levels of this substance may be present as a result of the specific characteristics of the raw materials and/or of the manufacturing process.

### ATRAZINE

We are pleased to provide the following information concerning the absence or presence of certain substances in the ExxonMobil Chemical product referenced above:

Atrazine (CAS no. 1912-24-9) is not intentionally used by ExxonMobil in this product. Although this product is not routinely tested for its presence, based on product composition knowledge this substance is not expected to be present. However, the fact that this substance is not intentionally used by ExxonMobil in this product does not exclude that trace levels of this substance may be present as a result of the specific characteristics of the raw materials and/or of the manufacturing process.

### BENZENE

**Product Name: ExxonMobil™ LDPE LD 653**

**Manufacturing Region: EUROPE**

---

We are pleased to provide the following information concerning the absence or presence of certain substances in the ExxonMobil Chemical product referenced above:

Benzene is not intentionally used by ExxonMobil in this product. Although this product is not routinely tested for its presence, based on product composition knowledge this substance is not expected to be present. However, the fact that this substance is not intentionally used by ExxonMobil in this product does not exclude that trace levels of this substance may be present as a result of the specific characteristics of the raw materials and/or of the manufacturing process.

## **BENZOPHENONE**

We are pleased to provide the following information concerning the absence or presence of certain substances in the ExxonMobil Chemical product referenced above:

Benzophenone, 4-methylbenzophenone and hydroxybenzophenones are not intentionally used by ExxonMobil in this product. Although this product is not routinely tested for their presence, based on product composition knowledge these substances are not expected to be present. However, the fact that these substances are not intentionally used by ExxonMobil in this product does not exclude that trace levels of these substances may be present as a result of the specific characteristics of the raw materials and/or of the manufacturing process.

## **BENZOTRIAZOLES**

We are pleased to provide the following information concerning the absence or presence of certain substances in the ExxonMobil Chemical product referenced above.

Benzotriazoles are not intentionally used by ExxonMobil in this product. Although this product is not routinely tested for their presence, based on product composition knowledge these substances are not expected to be present. However, the fact that these substances are not intentionally used by ExxonMobil in this product does not exclude that trace levels of these substances may be present as a result of the specific characteristics of the raw materials and/or of the manufacturing process.

## **BHT-BUTYLATED HYDROXY TOLUENE**

We are pleased to provide the following information concerning the absence or presence of certain substances in the ExxonMobil Chemical product referenced above.

Although BHT (Butylated Hydroxy Toluene) (CAS no. 128-37-0) is not intentionally used by ExxonMobil in this product, nor is this product routinely tested for its presence, there is some indication that trace levels of BHT (Butylated Hydroxy Toluene) may be present as a result of the specific characteristics of the raw materials and/or of the manufacturing process.

## **BISPHENOL A & F & S**

We are pleased to provide the following information concerning the absence or presence of certain substances in the ExxonMobil Chemical product referenced above:

Bisphenol A (BPA CAS no: 80-05-7), Bisphenol F (CAS no: 1333-16-0) and Bisphenol S (BPS CAS no: 80-09-1) are not intentionally used by ExxonMobil in this product. Although this product is not routinely tested for their presence, based on product composition knowledge these substances are not expected to be present. However, the fact that these substances are not intentionally used by ExxonMobil in this product does not exclude that trace levels of these substances may be present as a result of the specific characteristics of the raw materials and/or of the manufacturing process.

## **BLOWING AGENTS**

We are pleased to provide the following information concerning the absence or presence of certain substances in the ExxonMobil Chemical product referenced above:

The following blowing agents (azodicarbonamide (CAS no. 123-77-3), hydrazine derivatives, carbazoles and nitroso compounds, sodium borohydride (CAS no. 16940-66-2), CFCs, HCFCs) are not intentionally used by ExxonMobil in this product. Although this product is not routinely tested for their presence, based on product composition knowledge these substances are not expected to be present. However, the fact that these substances are not intentionally used by ExxonMobil in this product does not exclude that trace levels of these substances may be present as a result of the specific characteristics of the raw materials and/or of the manufacturing process.

## **BROMINE / BROMINE COMPOUNDS**

**Product Name: ExxonMobil™ LDPE LD 653**

**Manufacturing Region: EUROPE**

---

We are pleased to provide the following information concerning the absence or presence of certain substances in the ExxonMobil Chemical product referenced above.

Bromine and/or brominated compounds are not intentionally used by ExxonMobil in this product. Although this product is not routinely tested for their presence, based on product composition knowledge these substances are not expected to be present. However, the fact that these substances are not intentionally used by ExxonMobil in this product does not exclude that trace levels of these substances may be present as a result of the specific characteristics of the raw materials and/or of the manufacturing process.

Examples of brominated substances include, but are not limited to:

Polybrominated biphenyls (PBB), polybrominated diphenylethers, polybrominated terphenyls (PBTS), Bromobenzene, Bromochlorodifluoromethane, Bromotoluene Bromotrifluoromethane.

## **CHLORINE/CHLORINATED COMPOUNDS**

We are pleased to provide the following information concerning the absence or presence of certain substances in the ExxonMobil Chemical product referenced above.

Chlorine and/or chlorinated compounds are not intentionally used by ExxonMobil in this product. Although this product is not routinely tested for their presence, based on product composition knowledge these substances are not expected to be present. However, the fact that these substances are not intentionally used by ExxonMobil in this product does not exclude that trace levels of these substances may be present as a result of the specific characteristics of the raw materials and/or of the manufacturing process.

Examples of chlorinated substances include but are not limited to: Chlorinated Paraffins, Dichlorobenzene, Dichlorodifluoromethane, Dichlorotetrafluoroethane, Dichlorodiphenyltrichloroethane (DDT), Dieldrin, Dioxin, Hexachlorobenzene, Hexachlorobutadiene Methylene chloride, Octachlorostyrene, Pentachlorophenol, Chlorophenol, Polychlorinated Biphenyls-PCBs, Polychlorinated Diphenylethers, Polychlorinated Naphthalenes, Polychlorinated Terphenyls, Tetrachlorobenzene, Tetrachloroethylene, Trichlorobenzene, Trichloroethylene, Trichloromethane, Vinyl chloride, Polyvinyl chloride (PVC), Polyvinyl Dichloride (PVDC), Triclosan

## **COBALT / COBALT COMPOUNDS**

We are pleased to provide the following information concerning the absence or presence of certain substances in the ExxonMobil Chemical product referenced above:

Cobalt (CAS no. 7440-48-4) and/or its compounds are not intentionally used by ExxonMobil in this product. Although this product is not routinely tested for their presence, based on product composition knowledge these substances are not expected to be present. However, the fact that these substances are not intentionally used by ExxonMobil in this product does not exclude that trace levels of these substances may be present as a result of the specific characteristics of the raw materials and/or of the manufacturing process.

## **COLORANTS**

We are pleased to provide the following information concerning the absence or presence of certain substances in the ExxonMobil Chemical product referenced above:

Colorants (and dyes), including organic types, mineral types, titanium based, chromium based, lead based, cadmium based, cobalt based, nickel based, aluminum based, diazo types, anthraquinone types, monoazo types, and carbon black types, are not intentionally used by ExxonMobil in this product. Although this product is not routinely tested for their presence, based on product composition knowledge these substances are not expected to be present. However, the fact that these substances are not intentionally used by ExxonMobil in this product does not exclude that trace levels of these substances may be present as a result of the specific characteristics of the raw materials and/or of the manufacturing process.

## **DIOXIN**

We are pleased to provide the following information concerning the absence or presence of certain substances in the ExxonMobil Chemical product referenced above:

2,3,7,8-Tetrachlorodibenzo-p-dioxin (TCDD) (CAS no. 1746-01-6) is not intentionally used by ExxonMobil in this product. Although this product is not routinely tested for its presence, based on product composition knowledge this substance is not expected to be present. However, the fact that this substance is not intentionally used by ExxonMobil in this product does not exclude that trace levels of this substance may be present as a result of the specific characteristics of the raw materials and/or of the manufacturing process.

## **ELEMENTAL IMPURITIES**

**Product Name: ExxonMobil™ LDPE LD 653**

**Manufacturing Region: EUROPE**

We are pleased to provide the following information concerning the absence or presence of certain substances in the ExxonMobil Chemical product referenced above:

The following (heavy) metals/ transition metals / metalloids and/or their compounds

- Gold CAS no. 7440-57-5
- Iridium CAS no. 7439-88-5
- Osmium CAS no. 7440-04-2
- Palladium CAS no. 7440-05-3
- Platinum CAS no. 7440-06-4
- Rhodium CAS no. 7440-16-6
- Ruthenium CAS no. 7440-18-8
- Thallium CAS no. 7440-28-0
- Lithium CAS no. 7439-93-2
- Molybdenum CAS no. 7439-98-7
- Chromium CAS no. 7440-47-3

are not intentionally used by ExxonMobil in this product.

Although this product is not routinely tested for their presence, based on product composition knowledge these substances are not expected to be present. However, the fact that these substances are not intentionally used by ExxonMobil in this product does not exclude that trace levels of these substances may be present as a result of the specific characteristics of the raw materials and/or of the manufacturing process.

## ETHYLBENZENE

We are pleased to provide the following information concerning the absence or presence of certain substances in the ExxonMobil Chemical product referenced above.

Ethylbenzene (CAS no. 100-41-4) is not intentionally used by ExxonMobil in this product. Although this product is not routinely tested for its presence, based on product composition knowledge this substance is not expected to be present. However, the fact that this substance is not intentionally used by ExxonMobil in this product does not exclude that trace levels of this substance may be present as a result of the specific characteristics of the raw materials and/or of the manufacturing process.

## FLAME RETARDANTS

We are pleased to provide the following information concerning the absence or presence of certain substances in the ExxonMobil Chemical product referenced above:

The flame retardants

- Minerals such as aluminium hydroxide, magnesium hydroxide, hydromagnesite and borates salts
- Organohalogen compounds including organochlorines such as, chlorendic acid derivatives and chlorinated paraffins; organobromines such as polybrominated biphenyls (PBB), polybrominated diphenyl ethers (PBDEs) and tetrabromobisphenol (TBBP-A) and hexabromocyclododecane (HBCD or HBCDD).
- Antimony trioxide
- Organophosphorus compounds such as organophosphates, tris(2,3-dibromopropyl) phosphate, TPP, RDP, BPADP, tri-o-cresyl phosphate, phosphonates such as DMMP and phosphinates. Chlorophosphates like TMCP - Tris(2-chloroisopropyl) phosphate-, and TDCP -Tris(1,3- dichloroisopropyl) phosphate

are not intentionally used by ExxonMobil in this product.

Although this product is not routinely tested for their presence, based on product composition knowledge these substances are not expected to be present. However, the fact that these substances are not intentionally used by ExxonMobil in this product does not exclude that trace levels of these substances may be present as a result of the specific characteristics of the raw materials and/or of the manufacturing process.

## FLUORINE

We are pleased to provide the following information concerning the absence or presence of certain substances in the ExxonMobil Chemical product referenced above.

Fluorine and/or fluorinated compounds are not intentionally used by ExxonMobil in this product. Although this product is not routinely tested for their presence, based on product composition knowledge these substances are not expected to be present. However, the fact that these substances are not intentionally used by ExxonMobil in this product does not exclude that trace levels of these substances may be present as a result of the specific characteristics of the raw materials and/or of the manufacturing process.

**Product Name: ExxonMobil™ LDPE LD 653**

**Manufacturing Region: EUROPE**

---

## **FORMALDEHYDE**

We are pleased to provide the following information concerning the absence or presence of certain substances in the ExxonMobil Chemical product referenced above:

Formaldehyde (CAS no. 50-00-0) is not intentionally used by ExxonMobil in this product. Although this product is not routinely tested for its presence, based on product composition knowledge this substance is not expected to be present. However, the fact that this substance is not intentionally used by ExxonMobil in this product does not exclude that trace levels of this substance may be present as a result of the specific characteristics of the raw materials and/or of the manufacturing process.

Degradation products ("fumes"), potentially including formaldehyde, can be formed during high temperature processing of this product.

## **FURANES / BENZOFURANES**

We are pleased to provide the following information concerning the absence or presence of certain substances in the ExxonMobil Chemical product referenced above:

Furane (CAS no. 100-00-9) and benzofurane (CAS no. 271-89-6) are not intentionally used by ExxonMobil in this product. Although this product is not routinely tested for their presence, based on product composition knowledge these substances are not expected to be present. However, the fact that these substances are not intentionally used by ExxonMobil in this product does not exclude that trace levels of these substances may be present as a result of the specific characteristics of the raw materials and/or of the manufacturing process.

## **GMO**

We are pleased to provide the following information concerning the absence or presence of certain substances in the ExxonMobil Chemical product referenced above:

Genetically modified organisms (plant, animal, microorganism or other organism) defined as any organism whose genetic material has been altered using genetic engineering techniques are not intentionally used by ExxonMobil in this product. Although this product is not routinely tested for their presence, based on product composition knowledge these substances are not expected to be present. However, the fact that these substances are not intentionally used by ExxonMobil in this product does not exclude that trace levels of these substances may be present as a result of the specific characteristics of the raw materials and/or of the manufacturing process.

## **HCFCS-HFCS-CFCS&OTHER HALONS**

We are pleased to provide the following information concerning the absence or presence of certain substances in the ExxonMobil Chemical product referenced above.

Hydrochlorofluorocarbons (HCFCs), Hydrofluorocarbons (HFCs), Chlorofluorocarbons (CFCs), Perfluorocarbons (PFCS), Bromochlorofluorocarbons and bromofluorocarbons are not intentionally used by ExxonMobil in this product. Although this product is not routinely tested for their presence, based on product composition knowledge these substances are not expected to be present. However, the fact that these substances are not intentionally used by ExxonMobil in this product does not exclude that trace levels of these substances may be present as a result of the specific characteristics of the raw materials and/or of the manufacturing process.

## **HEXAVALENT CHROMIUM COMPOUNDS**

We are pleased to provide the following information concerning the absence or presence of certain substances in the ExxonMobil Chemical product referenced above.

Hexavalent chromium compounds are not intentionally used by ExxonMobil in this product. Although this product is not routinely tested for their presence, based on product composition knowledge these substances are not expected to be present. However, the fact that these substances are not intentionally used by ExxonMobil in this product does not exclude that trace levels of these substances may be present as a result of the specific characteristics of the raw materials and/or of the manufacturing process.

## **IODINE / IODINE COMPOUNDS**

We are pleased to provide the following information concerning the absence or presence of certain substances in the ExxonMobil Chemical product referenced above:

Iodine (CAS no. 7553-56-2) and/or its compounds are not intentionally used by ExxonMobil in this product. Although this product is not routinely tested for their presence, based on product composition knowledge these substances are not expected to be present. However, the fact that these substances are not intentionally used by ExxonMobil in this product does not exclude that trace levels of these substances may be present as a result of the specific characteristics of the raw materials and/or of the manufacturing process.

## **ISOPROPYLTHIOXAN-THONE (ITX)**

**Product Name: ExxonMobil™ LDPE LD 653**

**Manufacturing Region: EUROPE**

---

We are pleased to provide the following information concerning the absence or presence of certain substances in the ExxonMobil Chemical product referenced above:

Isopropylthioxan-thone (ITX) is not intentionally used by ExxonMobil in this product. Although this product is not routinely tested for its presence, based on product composition knowledge this substance is not expected to be present. However, the fact that this substance is not intentionally used by ExxonMobil in this product does not exclude that trace levels of this substance may be present as a result of the specific characteristics of the raw materials and/or of the manufacturing process.

## **LATEX / NATURAL RUBBER**

We are pleased to provide the following information concerning the absence or presence of certain substances in the ExxonMobil Chemical product referenced above:

Latex / Natural rubber is not intentionally used by ExxonMobil in this product. Although this product is not routinely tested for its presence, based on product composition knowledge this substance is not expected to be present. However, the fact that this substance is not intentionally used by ExxonMobil in this product does not exclude that trace levels of this substance may be present as a result of the specific characteristics of the raw materials and/or of the manufacturing process.

## **MELAMINE**

We are pleased to provide the following information concerning the absence or presence of certain substances in the ExxonMobil Chemical product referenced above:

Melamine and/or cyanuric acid are not intentionally used by ExxonMobil in this product. Although this product is not routinely tested for their presence, based on product composition knowledge these substances are not expected to be present. However, the fact that these substances are not intentionally used by ExxonMobil in this product does not exclude that trace levels of these substances may be present as a result of the specific characteristics of the raw materials and/or of the manufacturing process.

## **METALS / METALLOIDS**

We are pleased to provide the following information concerning the absence or presence of certain substances in the ExxonMobil Chemical product referenced above:

The following (heavy) metals/ transition metals / metalloids and/or their compounds

Antimony / Antimony compounds Arsenic / Arsenic compounds Barium / Barium compounds Beryllium / Beryllium compounds Bismuth / Bismuth compounds Copper / Copper compounds Cadmium / Cadmium compounds Manganese / Manganese compounds Mercury / Mercury compounds Lead / lead compounds Selenium / selenium compounds Silver / silver compounds

are not intentionally used by ExxonMobil in this product. Although this product is not routinely tested for their presence, based on product composition knowledge these substances are not expected to be present. However, the fact that these substances are not intentionally used by ExxonMobil in this product does not exclude that trace levels of these substances may be present as a result of the specific characteristics of the raw materials and/or of the manufacturing process.

## **METHYLNAPHTHALENES/NAPHTHALENE**

We are pleased to provide the following information concerning the absence or presence of certain substances in the ExxonMobil Chemical product referenced above:

Naphthalene and/or Methylnaphthalenes are not intentionally used by ExxonMobil in this product. Although this product is not routinely tested for their presence, based on product composition knowledge these substances are not expected to be present. However, the fact that these substances are not intentionally used by ExxonMobil in this product does not exclude that trace levels of these substances may be present as a result of the specific characteristics of the raw materials and/or of the manufacturing process.

## **NICKEL / NICKEL COMPOUNDS**

We are pleased to provide the following information concerning the absence or presence of certain substances in the ExxonMobil Chemical product referenced above:

Nickel and its compounds are not intentionally used by ExxonMobil in this product. Although this product is not routinely tested for their presence, based on product composition knowledge these substances are not expected to be present. However, the fact that these substances are not intentionally used by ExxonMobil in this product does not exclude that trace levels of these substances may be present as a result of the specific characteristics of the raw materials and/or of the manufacturing process.

**Product Name: ExxonMobil™ LDPE LD 653**

**Manufacturing Region: EUROPE**

---

## **NITROSAMINES**

We are pleased to provide the following information concerning the absence or presence of certain substances in the ExxonMobil Chemical product referenced above.

Nitrosamines are not intentionally used by ExxonMobil in this product. Although this product is not routinely tested for their presence, based on product composition knowledge these substances are not expected to be present. However, the fact that these substances are not intentionally used by ExxonMobil in this product does not exclude that trace levels of these substances may be present as a result of the specific characteristics of the raw materials and/or of the manufacturing process.

## **NONYLPHENOL & ...ETHOXYLATES**

We are pleased to provide the following information concerning the absence or presence of certain substances in the ExxonMobil Chemical product referenced above.

Nonylphenol, nonylphenoethoxylates, 4-octylphenol and octylphenoethoxylates are not intentionally used by ExxonMobil in this product. Although this product is not routinely tested for their presence, based on product composition knowledge these substances are not expected to be present. However, the fact that these substances are not intentionally used by ExxonMobil in this product does not exclude that trace levels of these substances may be present as a result of the specific characteristics of the raw materials and/or of the manufacturing process.

## **PALM OIL**

We are pleased to provide the following information concerning the absence or presence of certain substances in the ExxonMobil Chemical product referenced above.

Palm oil and/or palm kernel oil is not intentionally used by ExxonMobil in this product. Although this product is not routinely tested for its presence, based on product composition knowledge this substance is not expected to be present. However, the fact that this substance is not intentionally used by ExxonMobil in this product does not exclude that trace levels of this substance may be present as a result of the specific characteristics of the raw materials and/or of the manufacturing process.

## **PFOS & PFOA**

We are pleased to provide the following information concerning the absence or presence of certain substances in the ExxonMobil Chemical product referenced above:

Perfluorooctane sulfonate (PFOS) & Perfluorooctanoic acid (PFOA) are not intentionally used by ExxonMobil in this product. Although this product is not routinely tested for their presence, based on product composition knowledge these substances are not expected to be present. However, the fact that these substances are not intentionally used by ExxonMobil in this product does not exclude that trace levels of these substances may be present as a result of the specific characteristics of the raw materials and/or of the manufacturing process.

## **PHENOL**

We are pleased to provide the following information concerning the absence or presence of certain substances in the ExxonMobil Chemical product referenced above.

Phenol (CAS no. 108-95-2) is not intentionally used by ExxonMobil in this product. Although this product is not routinely tested for its presence, based on product composition knowledge this substance is not expected to be present. However, the fact that this substance is not intentionally used by ExxonMobil in this product does not exclude that trace levels of this substance may be present as a result of the specific characteristics of the raw materials and/or of the manufacturing process.

## **PHTHALATES/ADIPATES**

**Product Name: ExxonMobil™ LDPE LD 653**

**Manufacturing Region: EUROPE**

---

We are pleased to provide the following information concerning the absence or presence of certain substances in the ExxonMobil Chemical product referenced above.

Phthalate esters, such as

- benzyl butylphthalate
- dibutyl phthalate
- di-(2-ethylhexyl) phthalate
- diisononyl phthalate
- diisodecyl phthalate
- di-n-octyl phthalate and Adipates such as
- Bis(2-ethylhexyl) adipate (DEHA)
- Dimethyl adipate (DMAD)
- Dioctyl adipate (DOA)

are not intentionally used by ExxonMobil in this product. Although this product is not routinely tested for their presence, based on product composition knowledge these substances are not expected to be present. However, the fact that these substances are not intentionally used by ExxonMobil in this product does not exclude that trace levels of these substances may be present as a result of the specific characteristics of the raw materials and/or of the manufacturing process.

## **PRIMARY AROMATIC AMINES**

We are pleased to provide the following information concerning the absence or presence of certain substances in the ExxonMobil Chemical product referenced above:

Primary aromatic amines are not intentionally used by ExxonMobil in this product. Although this product is not routinely tested for their presence, based on product composition knowledge these substances are not expected to be present. However, the fact that these substances are not intentionally used by ExxonMobil in this product does not exclude that trace levels of these substances may be present as a result of the specific characteristics of the raw materials and/or of the manufacturing process.

Examples of primary aromatic amines include but are not limited to benzidine, aniline, toluidine and naphthylamines.

## **RADIOACTIVE SUBSTANCES**

We are pleased to provide the following information concerning the absence or presence of certain substances in the ExxonMobil Chemical product referenced above.

Radioactive substances are not intentionally used by ExxonMobil in this product. Although this product is not routinely tested for their presence, based on product composition knowledge these substances are not expected to be present. However, the fact that these substances are not intentionally used by ExxonMobil in this product does not exclude that trace levels of these substances may be present as a result of the specific characteristics of the raw materials and/or of the manufacturing process.

## **SILICONES / SILOXANES**

We are pleased to provide the following information concerning the absence or presence of certain substances in the ExxonMobil Chemical product referenced above.

Silicones / Polysiloxanes ( $[R_2SiO]_n$ ) are not intentionally used by ExxonMobil in this product. Although this product is not routinely tested for their presence, based on product composition knowledge these substances are not expected to be present. However, the fact that these substances are not intentionally used by ExxonMobil in this product does not exclude that trace levels of these substances may be present as a result of the specific characteristics of the raw materials and/or of the manufacturing process.

## **STYRENE**

We are pleased to provide the following information concerning the absence or presence of certain substances in the ExxonMobil Chemical product referenced above.

Styrene is not intentionally used as a functional component by ExxonMobil in this product. Although this product is not routinely tested for its presence, based on product composition knowledge this substance is not expected to be present. However, the fact that this substance is not intentionally used by ExxonMobil in this product does not exclude that trace levels of this substance may be present as a result of the specific characteristics of the raw materials and/or of the manufacturing process.

## **SUBST. OF VEGETABLE ORIGIN-GMO**

**Product Name: ExxonMobil™ LDPE LD 653**

**Manufacturing Region: EUROPE**

---

We are pleased to provide the following information concerning the absence or presence of certain substances in the ExxonMobil Chemical product referenced above:

Substances of vegetable origin are not intentionally used by ExxonMobil in this product. Although this product is not routinely tested for their presence, based on product composition knowledge these substances are not expected to be present. However, the fact that these substances are not intentionally used by ExxonMobil in this product does not exclude that trace levels of these substances may be present as a result of the specific characteristics of the raw materials and/or of the manufacturing process.

## **SULFUR**

We are pleased to provide the following information concerning the absence or presence of certain substances in the ExxonMobil Chemical product referenced above:

Sulfur and/or sulfur containing compounds are not intentionally used by ExxonMobil in this product. Although this product is not routinely tested for their presence, based on product composition knowledge these substances are not expected to be present. However, the fact that these substances are not intentionally used by ExxonMobil in this product does not exclude that trace levels of these substances may be present as a result of the specific characteristics of the raw materials and/or of the manufacturing process.

## **THIURAM MIX**

We are pleased to provide the following information concerning the absence or presence of certain substances in the ExxonMobil Chemical product referenced above:

- \* Tetramethylthiuram disulfide (CAS no. 137-26-8)
- \* Tetramethylthiuram monosulfide (CAS no. 97-74-5)
- \* Tetraethylthiuram disulfide (CAS no. 97-77-8)
- \* Dicyclopentamethylenethiuram disulfide (CAS no. 94-37-1)

are not intentionally used by ExxonMobil in this product.

Although this product is not routinely tested for their presence, based on product composition knowledge these substances are not expected to be present. However, the fact that these substances are not intentionally used by ExxonMobil in this product does not exclude that trace levels of these substances may be present as a result of the specific characteristics of the raw materials and/or of the manufacturing process.

## **TIN / ORGANOTIN COMPOUNDS**

We are pleased to provide the following information concerning the absence or presence of certain substances in the ExxonMobil Chemical product referenced above:

Tin and/or its compounds (including organotin compounds) are not intentionally used by ExxonMobil in this product. Although this product is not routinely tested for their presence, based on product composition knowledge these substances are not expected to be present. However, the fact that these substances are not intentionally used by ExxonMobil in this product does not exclude that trace levels of these substances may be present as a result of the specific characteristics of the raw materials and/or of the manufacturing process.

## **TNPP**

We are pleased to provide the following information concerning the absence or presence of certain substances in the ExxonMobil Chemical product referenced above.

Tris(nonylphenol)phosphite (TNPP) CAS no. 26523-78-4 is not intentionally used by ExxonMobil in this product. Although this product is not routinely tested for its presence, based on product composition knowledge this substance is not expected to be present. However, the fact that this substance is not intentionally used by ExxonMobil in this product does not exclude that trace levels of this substance may be present as a result of the specific characteristics of the raw materials and/or of the manufacturing process.

## **TOLUENE**

We are pleased to provide the following information concerning the absence or presence of certain substances in the ExxonMobil Chemical product referenced above.

Toluene is not intentionally used by ExxonMobil in this product. Although this product is not routinely tested for its presence, based on product composition knowledge this substance is not expected to be present. However, the fact that this substance is not intentionally used by ExxonMobil in this product does not exclude that trace levels of this substance may be present as a result of the specific characteristics of the raw materials and/or of the manufacturing process.

## **TOLUENE DIISOCYANATE (TDI)**

**Product Name: ExxonMobil™ LDPE LD 653**

**Manufacturing Region: EUROPE**

---

We are pleased to provide the following information concerning the absence or presence of certain substances in the ExxonMobil Chemical product referenced above:

Toluene diisocyanate (TDI) not intentionally used by ExxonMobil in this product. Although this product is not routinely tested for its presence, based on product composition knowledge this substance is not expected to be present. However, the fact that this substance is not intentionally used by ExxonMobil in this product does not exclude that trace levels of this substance may be present as a result of the specific characteristics of the raw materials and/or of the manufacturing process.

## **VANADIUM / VANADIUM COMPOUNDS**

We are pleased to provide the following information concerning the absence or presence of certain substances in the ExxonMobil Chemical product referenced above.

Vanadium and/or its compounds are not intentionally used by ExxonMobil in this product. Although this product is not routinely tested for their presence, based on product composition knowledge these substances are not expected to be present. However, the fact that these substances are not intentionally used by ExxonMobil in this product does not exclude that trace levels of these substances may be present as a result of the specific characteristics of the raw materials and/or of the manufacturing process.

## **XYLENES**

We are pleased to provide the following information concerning the absence or presence of certain substances in the ExxonMobil Chemical product referenced above:

Xylene is not intentionally used by ExxonMobil in this product. Although this product is not routinely tested for its presence, based on product composition knowledge this substance is not expected to be present. However, the fact that this substance is not intentionally used by ExxonMobil in this product does not exclude that trace levels of this substance may be present as a result of the specific characteristics of the raw materials and/or of the manufacturing process.

## **ZINC / ZINC COMPOUNDS**

We are pleased to provide the following information concerning the absence or presence of certain substances in the ExxonMobil Chemical product referenced above:

Zinc and/or its compounds are not intentionally used by ExxonMobil in this product. Although this product is not routinely tested for their presence, based on product composition knowledge these substances are not expected to be present. However, the fact that these substances are not intentionally used by ExxonMobil in this product does not exclude that trace levels of these substances may be present as a result of the specific characteristics of the raw materials and/or of the manufacturing process.

## **ZIRCONIUM /ZIRCONIUM COMPOUNDS**

We are pleased to provide the following information concerning the absence or presence of certain substances in the ExxonMobil Chemical product referenced above:

Zirconium and/or its compounds are not intentionally used by ExxonMobil in this product. Although this product is not routinely tested for their presence, based on product composition knowledge these substances are not expected to be present. However, the fact that these substances are not intentionally used by ExxonMobil in this product does not exclude that trace levels of these substances may be present as a result of the specific characteristics of the raw materials and/or of the manufacturing process.

**This document is valid for one year or until the next relevant legislative and or regulatory change with a maximum of one year as of the issue date.**

Gerresheimer Vaerloese A/S · Walgerholm 2-8 · DK-3500 Vaerloese · Denmark

## Plastic Packaging

Gerresheimer Vaerloese A/S  
Walgerholm 2-8  
3500 Vaerloese  
Denmark

Managing Director:  
Niels Düring

Registered Seat: Vaerloese  
VAT No. 10417430

e-mail      katarzyna.jawor@gerresheimer.com  
Internet     www.gerresheimer.com

September 16, 2020

Based upon information from supplier of masterbatch, Gerresheimer Vaerloese A/S hereby confirms that 18-2440-PBL-7 has supplier product name PEFB3060.

Yours sincerely,



Katarzyna Jawor

Compliance Specialist

Primary Packaging Plastics



Hubron (International) Limited

Albion Street,  
Failsworth, Manchester,  
M35 0FP, England

Tel: +44(0)161 681 2691  
Fax: +44(0)161 683 4658  
E-mail: [sales@hubron.com](mailto:sales@hubron.com)  
Web: [www.hubron.com](http://www.hubron.com)

## Product Compliance

### Black Masterbatch PEFB 3060

#### European Union:

**Framework regulation (EC) 1935/2004 and European Commission Regulation (EU) No 10/2011 of 14<sup>th</sup> January 2011 on plastic materials and articles intended to come into contact with food:**

The composition of PEFB 3060 complies with the relevant requirements of the above framework and commission regulation when dosed at a **maximum 6.25% w/w**.

The monomers/ additives used in the formulation are listed in the positive list (Annex I; Table 1 or 2 of [EU]10/2011) with the following migration restrictions: **None**

The following Dual Use Additives are present in PEFB 3060: E471

Other additives associated with the masterbatch polymer carrier.  
Dual use additives = **None**

The above statement remains unaffected by Commission Regulation (EU) No 321/2011, (EU) No 1282/2011, (EU) No 1183/2012, (EU) No 202/2014 (EU) No 174/2015, (EU) No 1416/2016, (EU) No752/2017, (EU) No79/2018, (EU) No 213/2018, (EU) No 2019/37, (EU) No 988/2019, (EU) 2019/1338 and (EU) 2020/1245.

Black masterbatch PEFB 3060 is manufactured using good manufacturing practices as specified by Regulation (EC) No 2023/2006.

The above mentioned masterbatch is manufactured using a carbon black material which is in accordance with **European Resolution AP (89) 1** 'on the use of colourants in plastic materials coming into contact with food'

#### **REACH Regulation (EC) 1907/2006 & Commission Regulation (EU) No 1272/2013**

Raw materials and processes used in the manufacture of PEFB 3060 none are listed on the SVHC List issued 19/01/2020 (211 Items).

No substances listed in Annex XIV of the above regulation are used in the manufacture of PEFB 3060.

No substances listed in Annex XVII of the above regulation are used in the manufacture of PEFB 3060 with the exception of Polycyclic Aromatic Hydrocarbons (PAHs) which are encapsulated on the carbon black surface.

Polycyclic Aromatic Hydrocarbons (PAHs) are associated with carbon black and are present in trace levels on the surface of all carbon blacks. Hubron products fully encapsulate the carbon black pigment in a polymer matrix and as such any PAHs present are contained.

Typical total PAH content of carbon black grades used do not generally exceed 0.1% and levels of individual components such as benzo(a)pyrene varies considerable from grade to grade.

Annex XVII of Commission Regulation (EU) No 1272/2013 states that in certain applications where prolonged or short-term repetitive contact with human skin or the oral cavity is likely. The individual PAH content in a component should be lower than 1PPM. For toy applications, this is reduced further to 0.5PPM.

The above mentioned masterbatch contains 40% carbon black with the purity as specified above. Therefore, at the maximum masterbatch recommended dosage for food contact applications of 6.25%, the contribution of individual PAHs to a finished component is only 0.025PPM

Use of Perfluorooctanoic acid PFOA:

I can confirm that Hubron **do not** use PFOA, PFOS or any related substances (including salts and polymers) in the manufacture of PEFB 3060.

#### **Packaging and Packaging Waste Directive 94/62/EC**

Hubron masterbatches as listed below contain pigments with total levels of lead, cadmium, mercury and hexavalent chromium below 100PPM.

The above-mentioned materials are therefore in compliance with Article 11 of the above Directive

The above statement is unaffected by the amending Directives 99/177/EC, 2004/12/EC and 2005/20/EC.

#### **End-of Life Vehicle Directive 2000/53/EC**

The above mentioned masterbatches are NOT classified as hazardous as described, under directive (EU) 1272/2013. The above mentioned masterbatch only contains trace amounts of lead, mercury, cadmium and hexavalent chromium (<100PPM) unintentionally present.

Compliance with Directive 2000/53/EC of the European Parliament and of the Council of 18 September 2000 on end-of life vehicles, and its subsequent amendments 2002/525/EC, 2005/438/EC and 2005/673/EC must be determined by the end user.

#### **Persistent Organic Pollutants (EU) 2019/1021**

No substances listed in Annex I – IV are used in the manufacture of PEFB3060. Annex III states that PAHs should be subject to release reduction provisions.

PAHs are associated with carbon black and are present at trace levels on the surface of carbon black. The carbon black used in PEFB3060 meets the purity requirements outlined in (EU) 10/2011.

#### **2011/65/EU on the restriction of the use of certain hazardous substances in electrical and electronic equipment:**

Annex II of 2011/65/EU lists substances that have maximum permitted concentration values. Black Masterbatch PEFB 3060 does **not** contain the substances PBB or PBDE mentioned in Annex II of 2011/65/EU.

The above mentioned masterbatch does contain trace levels of Lead, Mercury, Cadmium and Chromium however, levels of individual substances should not typically exceed those indicated in Annex II of 2011/65/EU.

(EU) 2015/863 amends directive 2011/65/EU by listing a further 4 substances with maximum concentration values that are not to be exceeded. The above mentioned masterbatch does **not** contain any of the 4 substances listed (DEHP, BBP, DBP, DIBP)

#### **Phthalates in toys and childcare articles 2005/84/EC**

Black Masterbatch PEFB 3060 does not contain any of the phthalates DEHP, DBP, BBP, DINP, DIDP and DNOP as listed in the annex of the above directive.

The above mentioned masterbatch does not therefore contain any Phthalates and is compliant with the 22nd amendment of 76/769/EEC – 2005/84/EC

#### **Directive 2009/48/EC Safety of Toys & EN71**

Black Masterbatch PEFB 3060 is manufactured using raw materials in accordance with EN71-3:2013+A3:2018 in that they contain levels of heavy metals as listed in Table 2 'Migration limits from toy materials' that are lower

than the maximum permissible limits as indicated in the table for Category III materials, when the masterbatch is used at <6.25% addition level.

PEFB 3060 does not contain any substances listed in EN71-9:2005+A1:2007 and also complies to with changes to EN71-9 effective 4th November 2018 relating to Phenol content and migration.

PEFB 3060 does not contain any substances as intentionally added ingredients listed in Annex II of 2009/48/EC Section 3 part 11 relating to allergenic fragrances

#### **Regulation (EC) No 1223/2009 on Cosmetic Products**

PEFB 3060 does not contain any substances listed in Annex II and III of No 1223/2009 of substance not suitable for use in cosmetics.

Carbon black is listed in Annex IV of No 1223/2009 under colourants allowed in cosmetics products.

#### **GADSL**

This is to certify that no ingredients are listed in the GADSL Reference List revised 01/02/2020 with exception to Polycyclic Aromatic Hydrocarbons (PAH).

The individual PAH content in a component should be less than 1 PPM for any of the PAHs regulated by REACH Annex XVII. Data supplied by the carbon black producers of the specific grades used in PEFB 3060. shows that typical individual PAH levels do not exceed 1PPM. This information is based on occasional testing of the carbon black and does not form a specification/guaranteed level.

Testing should be carried out on the final article to confirm GADSL compliance, suggested recommended dosage <6.25%.

#### **Regulation (EU) No 528/2012 Biocidal Products**

PEFB 3060 does not contain any substances listed in the above regulation.

#### **Conflict Minerals**

The ingredients used constitutionally do not contain any derivatives:

- Gold
- Tin
- Tantalum
- Tungsten
- Wolframite
- Cassiterite
- Coltan
- Any other minerals or derivatives determined by the US Secretary of State to be financing conflict in the DRC or adjoining countries as stipulated in Section 1502 of the Dodd-Frank Act.

To clarify these conflict minerals are neither present in the raw materials we use, nor have they been intentionally added during the manufacturing process of the above mentioned masterbatch.

#### **North America:**

#### **FDA**

Not Compliant

#### **CONEG**

Hubron masterbatches as listed below contain pigments with total levels of lead, cadmium, mercury and hexavalent chromium below 100PPM. The above is therefore in compliance.

## California Proposition List 65 (December 18<sup>th</sup>, 2020 – Chemicals Known to the State to Cause Cancer or Reproductive Toxicity)

Black Masterbatch PEFB 3060 is based on a carbon black pigment which is listed. The carbon black is fully encapsulated and is **NOT** airborne or unbound. No other substances listed are present with the exception of trace levels of heavy metals and Polycyclic Aromatic Hydrocarbons (PAHs) where these quantities are within permissible limits.

### China:

#### Hygienic Standards for uses of additives in food containers and packaging materials (GB 9685-2016, 4806.6 and 4806.7)

The carbon black used in PEFB 3060 meets the purity requirements listed in Appendix A table A1 of GB9685-2016 with maximum content 'use appropriately according to the production demand'.

PEFB 3060 comprises a resin which is listed in PRC National Standard GB 4806.6-2016, Table A.1., entry 101 (CAS 9010-79-1) and complies with any applicable requirements for that resin, as tested with the above material or a comparable grade.

This material contains no monomers which are regulated with a restriction in their use.

This material does not contain additives which are regulated with a restriction in their use.

PEFB 3060 is suitable for producing articles suitable for food contact. Recommended maximum dosage is 6.25% w/w. PEFB 3060 has been manufactured according to the requirements laid down by the General Hygiene regulations GB 31603-2015.

### Japan:

PEFB 3060 is compliant with the Positive List, effective 28<sup>th</sup> April 2020 (MHLW Notification No 196) of substances related to food contact material in Japan, as mentioned in Section III of the Standards and specification for foods and food additives, Etc. (MHLW Notification No 370, effective June 2018) Under the food Sanitation Act (Act No 233 of 1947). We inform you that this Positive List is effective since 1<sup>st</sup> June 2020.

I confirm the polymers used in the manufacture of PEFB 3060 are listed in Table 1 (1) Base Polymer in the Category 40 (Polyethylene) with reference number 985 entry 4: ethylene homopolymer CAS 9002-88-4 and that the monomer used is listed in Table 1 (3) in Category 4 Hydrocarbon entry 5: ethylene CAS 74-85-1.

I can confirm that all additives (if any) used in the polymer carrier are listed on Table 2 and are below the permitted levels mentioned for Group 5.

整理番号 Ref. No.	通し番号 No.	物質名 Substance		CAS登録 番号 CAS Registry Number	食品区分 Food Category					最高温度 Maximum Temperature	合成樹脂区分 Synthetic Resin Group	特記事項 Requirements
		和名 Japanese Name	英名 English Name		酸性食品 Acidic	油脂及び脂 肪性食品 Fat/oil and fatty/oily	乳・乳製 品 Milk/milk product	酒類 Alcoholic beverage	その他の食 品 Others			
985	4	エチレン単独重合体	ethylene homopolymer	9002-88-4	○	○	○	○	○	III	5	

The carbon black used in the manufacture of PEFB3060 meets the purity requirements as outlined in JHOSPA.

### Others:

#### BSE/TSE

The above mentioned masterbatch is based on Polyethylene and contains a carbon black pigment. No additives are intentionally added. Information from suppliers confirms that these products are free from Bovine Spongiform Encephalopathy (BSE) and Transmissible Spongiform Encephalopathy (TSE).

Additionally, the raw materials used in the manufacture of PEFB 3060 are not derived from animal sources.

PEFB 3060 does not contain in the manufacture or as NIAS:

**2-Isopropyl-thioxanthone (ITX)**  
**2-Ethylhexyl-4-dimethylaminobenzoate (EHDAB)**  
**4-hydroxybenzophenon**  
**4-methylbenzophenon**  
**Allergens**  
**Antimony trioxide**  
**Benzophenon**  
**Bisphenol A [chemical name: 2,2-bis(4-hydroxyphenyl) propane] (CAS# 80-05-7)**  
**Chloramines**  
**Chlorine**  
**Dibutylamine**  
**diethanolamine**  
**diethylacetamide (DEA)**  
**diethylamine**  
**Diethylamine**  
**Dimethylamine**  
**Dinitrogen tetraoxide (N<sub>2</sub>O<sub>4</sub>)**  
**Dinitrogen trioxide (N<sub>2</sub>O<sub>3</sub>)**  
**Epoxidized soybean oil (ESBO)**  
**Formaldehyde**  
**HNO<sub>2</sub> (Nitrous Acid)**  
**HNO<sub>3</sub> (Nitric Acid)**  
**Latex**  
**Melamine**  
**Monoethylamine**  
**N,N-dimethylacetamide (DMA)**  
**N,N-dimethylformamide (DMF)**  
**NaNO<sub>2</sub> (Sodium Nitrite)**  
**NH<sub>2</sub>OH (Hydroxylamine)**  
**Nitrocellulose**  
**Nitrofurazone**  
**Nitrosamines**  
**Nitrosyl halides (e.g. ClNO, BrNO)**  
**N-Methylmorpholine (NMM)**  
**N-Methylpyrrolidine (NMP)**  
**N-Nitrosodiethylamine (NDEA) and N-Nitroso-N-methyl-4-aminobutyric acid (NMBA)**  
**N-Nitrosodimethylamine (NDMA),**  
**N-nitrosodiisopropylamine (DIPNA) i N-nitrosoethylisopropylamine (EIPNA).**  
**NO (Nitric Oxide)**  
**Organic nitrites (e.g. t-BuONO)**  
**Ozone**  
**secondary or tertiary amines, quaternary alkyl ammonium salts or alkyl amides**  
**Semicarbazide**  
**Tetra Butyl Ammonium Bromide (TBAB)**  
**Tributylamine (TBA)**  
**Triethylamine**

**Trimethylamine**

For Hubron



.....  
Mr R. Laurent – Technical Manager  
25<sup>th</sup> January 2021.

Hubron (Int) Ltd cannot be held responsible as a masterbatch producer, for the application in which the product is put by the converter/user. Overall and specific migration is another aspect of the commission regulation. This aspect often depends on the end use conditions, and it is the responsibility of the converter/user of the masterbatch to assure migration compliance of the final product for the intended usage conditions.

The information given above is true and accurate at the time given and it is based on documentation provided by raw material suppliers. Hubron holds no responsibility for the compliance of finished components or compounds, as additional processing and the use of other compound ingredients is beyond our control



## Food contact declaration

### Company

A. Schulman Plastics BVBA  
Pedro Colomalaan 25  
B-2880 Bornem - Belgium  
T +32-3-890 42 11  
[ASI-productsafety.emea@lyondellbasell.com](mailto:ASI-productsafety.emea@lyondellbasell.com)

### General info

PRODUCT	<b>POLYBATCH CE 505 NATURAL ASBAG 25</b>
PRODUCT CODE	11760301
VERSION	3.20
VALID TO	This document is valid until the next relevant legislative, regulatory and /or compositional change.
CONCLUSION EU	Based on the info received from our suppliers of the raw materials, we confirm that the composition complies with the EU legislation as mentioned below for the different component types. It is up to the producer of the finished article to verify that migration limitation is not exceeded.

### European Union

1935/2004/EC	This product complies with the relevant requirements of Regulation (EC) No 1935/2004 (Framework Regulation) as applicable to intermediate materials.
2023/2006/EC	This product complies with the relevant requirements of Good Manufacturing Practice (EC) No 2023/2006 (including all amendments) applicable to intermediate materials.
EU 10/2011	All the polymers and intentionally added additives comply with the requirements of Regulation (EU) No 10/2011 and its amendments, applicable to intermediate materials; published before the print date of this document. Information regarding components subject to further specific limitations and concerning the presence of dual-use additives is given hereunder.
Migration Limits	Ref No Annex II - Zinc - 5 mg/kg SML FCM No 433 - Ref No 68320 - 6 mg/kg SML
Dual use additives	There is no declarable migrating additive which is subject to a restriction in food as referred to in Article 11 item 3 of Commission Regulation (EU) No 10/2011.
Concentration value	Ref No Annex II - Zinc - 0,0323% FCM No 433 - Ref No 68320 - 0,0064%

### Responsibility

Appropriate overall and specific migration tests on the final material or article will determine the regulatory suitability for contact with different food types and various end-use conditions. However these are beyond the control of LyondellBasell and are a part of the responsibility of the user of this product.

**Statement managed by LyondellBasell – Product Safety Department**

Date :26/03/2020

This document is created electronically and is valid without signature.

Original text: English

Information in this document is accurate to the best of our knowledge at the date of publication. The document is designed to provide users general information for safe handling, use, processing, storage, transportation, disposal and release and does not constitute any warranty or quality specification, either express or implied, including any warranty of merchantability or fitness for any particular purpose. Users shall determine whether the product is suitable for their use and can be used safely and legally.

In addition to any prohibitions of use specifically noted in this document, LyondellBasell may further prohibit or restrict the sale of its products into certain applications. For further information, please contact a LyondellBasell representative or visit the LyondellBasell website at:



<https://www.lyondellbasell.com/en/products-technology/product-safety-stewardship/>  
The Trademark referenced within the product name is owned or used by the LyondellBasell family of companies.

## COSMETICS DECLARATION

**117603      POLYBATCH CE 505**  
**225320      POLYBATCH PP-18013**

In response to your request we can confirm that the above-mentioned product does not contain any intentional additives of the below referenced substances.

**REACH – SVHC above the thresholds of 0,1 % as listed and defined in the relevant EU directive**

- Candidate list of substances of very high concern (SVHC) in accordance with Article 59(10) of the REACH regulation as published by ECHA on June 25, 2020.

**Heavy metals**

- Directive 94/62/EC of 20 December 1994 on packaging and packaging waste

**Substances above the thresholds as listed and defined in the relevant CLP Regulation 1272/2008 Annex VI**

- CMR SUBSTANCES
- SKIN SENSITIZERS

**REGULATION (EC) No 1223/2009 of 30 November 2009 on cosmetic products**

- SUBSTANCES LISTED ON ANNEX II - SUBSTANCES PROHIBITED IN COSMETIC PRODUCTS

The absence of above substances has not been verified by analysis or tests by LyondellBasell and is declared based on the information available to us from our raw material suppliers. The info we receive from our suppliers is info which they are legally obliged to share with their downstream users.

It can therefore not be excluded that trace levels of these substances may be unintentionally present (amongst others because they may be ubiquitous in the environment) or may result from the specific characteristics of the raw materials or the manufacturing process. It is the responsibility of the recipient of our products to ensure that any local applicable rules and legislation are observed.

This document is valid until the next relevant legislative and/or regulatory change.

---

**Statement managed by LyondellBasell – Product Safety Department**

Issue date: September 22, 2020



implied, including any warranty of merchantability or fitness for any particular purpose. Users shall determine whether the product is suitable for their use and can be used safely and legally.

In addition to any prohibitions of use specifically noted in this document, LyondellBasell may further prohibit or restrict the sale of its products into certain applications. For further information, please contact a LyondellBasell representative or visit the LyondellBasell website at: <https://www.lyondellbasell.com/en/products-technology/product-safety-stewardship/>

The Trademark referenced within the product name is owned or used by the LyondellBasell family of companies.

## PRODUCT REGULATORY INFORMATION SHEET

<b>109557</b>	<b>POLYBATCH 3510 E</b>
<b>117603</b>	<b>POLYBATCH CE 505</b>
<b>210624</b>	<b>POLYBATCH GP-28035</b>
<b>211546</b>	<b>POLYBATCH GP-28056</b>
<b>211675</b>	<b>POLYBATCH GP-28061</b>
<b>225320</b>	<b>POLYBATCH PP-18013</b>

We certify, that during manufacturing of this product, we do not use or intentionally incorporate into it, any of the chemicals as restricted by the following regulations and their subsequent amendments in amounts which exceed the applicable limits.

- Directive 2011/65/EC (Restriction of the use of certain Hazardous Substances in electrical and electronic equipment - RoHS)
  - Cr(VI), Hg, Pb, PBB and PBDE < 0.1 wt%, Cd < 0.01 wt%
- Directive 2012/19/EC (Waste Electrical & Electronic Equipment - WEEE) - Annex II
  - No ingredients used which require selective waste treatment (As, Hg, PCB, PCT, CFC, HCFC, HFC, brominated FR)
- Directive 2000/53/EC (End of life vehicles - ELV)
  - Cr(VI), Hg and Pb < 0.1 wt%, Cd < 0.01 wt%
- Directive 94/62/EC (Packaging and packaging waste) and US CONEG "Toxics in Packaging" Regulation, as amended
  - Sum of Cd, Cr, Hg and Pb < 100 ppm

Regarding classification of the above product according to REGULATION (EC) No 1272/2008 and its subsequent amendments, reference is made in the SDS for the above product.

We also certify that during the manufacturing of the above product we do not use or intentionally incorporate into it any of the following materials:

- Candidate list of substances of very high concern in accordance with Article 59(10) of the REACH regulation as published by ECHA on June 25, 2020.
- Dimethyl fumarate – Cas 624-49-7 In relation to Commission Decision (EC) 2009/251
- Organotin compounds (TBT, DBT, MBT)

- Bisphenol A (CAS No 80-05-7) / Bisphenol F / Bisphenol S / Bisphenol B
- Other epoxy derivatives, BADGE, BFDGE or NOGE
- Latex / natural rubber
- PVC and PVC compounds, Vinyl Chloride, PVDC (Polyvinylidene chloride)
- Melamine
- Nitrosamines

- **SUBSTANCES OF ANIMAL ORIGIN**

Be aware that a pigment used in the above batch may contain traces of substances of animal origin. The materials of animal origin in these carriers are conform to the requirements regarding origin and specified risk materials as defined in Regulation 1069/2009, or originate from countries considered as BSE-free.

EXCEPT for POLYBATCH CE505 which does contain intentionally added substances of animal origin as additives.

The materials of animal origin used for the production of additives are conform to the requirements regarding origin and specified risk materials as defined in regulation 1069/2009.

Furthermore, temperature and pressure as employed for the production of plastic additives from these materials surpass the conditions as laid down in directives 1069/2009/EC, and 142/2011/EC, and the "Note for Guidance EMA/410/01.

- **Engineered nanomaterials**

Of course, it is well known that many powders (dyestuffs, pigments and additives) used in the production of masterbatches /compounds include particles in the nano range. The lowest part of the particle size distribution of those powders can be in the nano range. Those powders are not marketed as nanomaterials, nor are they necessarily specifically engineered or manufactured to be in the <100nm range. In polymer applications these powders are encapsulated in the polymer matrix.

- Recyclates/Recycled materials according to Commission regulation (EU) 282/2008/EC of 27 March 2008 and amended up to (EU) 2015/1906 of 22 October 2015 on recycled plastic materials and articles intended to come into contact with foods.

- **Perfluorooctanoic acids (PFOA)**

Substance	CAS No,
Ammonium pentadecafluorooctanoate	3825-26-1
Pentadecafluorooctanoic acid	335-67-1
Ethylperfluorooctanoate	3108-24-5
Methylperfluorooctanoate	376-27-2
Pentadecafluorooctyl fluoride	335-66-0
Sodium pentadecafluorooctanoate	335-95-5

- **Perfluorooctanoic sulfonates (PFOS)**

Substance	CAS No,
Heptadecafluorooctane-1-sulphonic acid	1763-23-1
Potassium heptadecafluorooctane-1-sulphonate	2795-39-3
Ammonium heptadecafluorooctanesulphonate	29081-56-9
Lithium heptadecafluorooctanesulphonate	29457-72-5
Tetraethylammonium heptadecafluorooctanesulphonate	56773-42-3
Heptadecafluorooctanesulphonyl fluoride	307-35-7

- Azodyes classified according our suppliers that may form carcinogenic amines

Substance	CAS No,
C.I. Acid Red 5, C.I.14905	5858-63-9
C.I. Basic Red 111	118658-98-3
C.I. Direct Black 38, C.I.30235	1937-37-7
C.I. Direct Blue 1, C.I.24410	2610-05-1
C.I. Direct Blue 2, C.I.22590	2429-73-4
C.I. Direct Blue 3, C.I.23705	2429-72-3
C.I. Direct Blue 6, C.I.22610	2602-46-2
C.I. Direct Blue 14, C.I.23850	72-57-1
C.I. Direct Blue 295, C.I.23820	6420-22-0
C.I. Direct Brown 2, C.I.22311	2429-82-5
C.I. Direct Brown 6, C.I.30140	2893-80-3
C.I. Direct Brown 31, C.I.35660	2429-81-4
C.I. Direct Red 1, C.I.22310	2429-84-7
C.I. Direct Red 2, C.I.23500	992-59-6
C.I. Direct Red 10, C.I.22145	2429-70-1
C.I. Direct Red 28, C.I.22120	573-58-0
C.I. Direct Red 37, C.I.22240	3530-19-6
C.I. Direct Red 39, C.I.23630	6358-29-8
C.I. Disperse Yellow 7, C.I.26090	6300-37-4
Trisodium bis(6-(4-anisidino)-3-sulfonato-2-(3,5-dinitro-2-oxidophenylazo)-1-naphtholato)chromate(1-)	118685-33-9

- Phthalates

Substance	CAS No,
Di-n-butyl phthalate	CAS 84-74-2
Di-isobutyl phthalate	CAS 84-69-5
Di-n-pentyl phthalate	CAS 131-18-0
Butyl benzyl phthalate	CAS 85-68-7
Di-n-hexyl phthalate	CAS 84-75-3
Di(2-ethylhexyl) phthalate	CAS 117-81-7
Diisopentylphthalate	CAS 605-50-5
Bis(2-methoxyethyl) phthalate	CAS 117-82-8
1,2-benzenedicarboxylic acid, mixed decyl and hexyl and octyl diesters with $\geq 0.3\%$ of dihexyl phthalate	CAS 68648-93-1
1,2-benzenedicarboxylic acid, di-C6-10-alkyl esters	CAS 68515-51-5
1,2-Benzenedicarboxylic acid; di-C6-8-branched alkylesters, C7-rich	CAS 71888-89-6
Heptyl undecyl phthalate	CAS 68515-42-4

- Allergens as listed in Annex II of Regulation (EU) No 1169/2011 on the provision of food information to consumers

Allergen	Product contains this allergen (YES/NO)	Product is produced on same equipment or in same facility where these allergens are used/present (YES/NO)
Cereals containing gluten ( i.e. wheat, Corn, rye, barley, oats, spelt, kamut or their hybridised strains) and products thereof	NO	NO
Crustaceans and products thereof	NO	NO
Eggs and products thereof	NO	NO
Fish and products thereof	NO	NO
Peanuts and products thereof	NO	NO
Soybeans and products thereof	NO	NO
Milk and products thereof (including lactose)	NO	NO
Nuts *(see below) and products thereof	NO	NO
Celery and products thereof	NO	NO
Mustard and products thereof	NO	NO
Sesame seeds and products thereof	NO	NO

Sulphur dioxide and sulphites (concentrations of more than 10 mg/kg or 10 mg/litre, as SO <sub>2</sub> )	NO	NO
Lupines and products thereof	NO	NO
Moluscs and products thereof	NO	NO

\* Almond (*Amygdalus communis L.*), Hazelnut (*Corylus avellana*), Walnut (*Juglans regia*), Cashew (*Anacardium occidentale*), Pecan nut (*Carya illinoensis* (Wangenh.) K. Koch), Brazil nut (*Bertholletia excelsa*), Pistachio nut (*Pistacia vera*), Macadamia nut and Queensland nut (*Macadamia ternifolia*).

- Genitically modified organisms (GMO)  
However, our suppliers also use some substances derived from organisms as starting materials for synthesis or components of mixtures (e. g. fatty acid derived alcohols or enzymes). Due to the complexity of the channels of trade, it cannot be excluded that some of these raw materials may originate from, but do not themselves contain, genetically modified organisms (GMO's). Such raw materials pass through a range of chemical transformation processes and purification steps and are, therefore, considered to be safe.

Ref.:

DIRECTIVE 2001/18/EC OF THE EUROPEAN PARLIAMENT AND OF THE COUNCIL of 12 March 2001 on the deliberate release into the environment of genetically modified organisms and repealing Council Directive 90/220/EEC

- Persistent Organic Pollutants set out in the Stockholm Convention and Commission Regulation EU 519/2012 of 19 June 2012 amending Regulation (EC) No. 850/2004.

Substance	CAS No,
Aldrin	309-00-2
Chlordane	57-74-9
Dieldrin	60-57-1
Endrin	72-20-8
Heptachlor	76-44-8
Hexachlorobenzene	118-74-1
Mirex	2385-85-5
Toxaphene	8001-35-2
Polychlorinated Biphenyls (PCB)	1336-36-3 and others
DDT (1,1,1-trichloro-2,2-bis(4-chlorophenyl) ethane)	50-29-3
Chlordecone	143-50-0
Hexabromobiphenyl	36355-01-8
HCH, including lindane	608-73-1, 58-89-9
Polychlorinated dibenzo-p-dioxines and dibenzofurans (PCDD/PCDF)	

- Ozone depleting substances according Reg. (EC) No 1005/2009; Montreal Protocol; US EPA Class 1 ODS

Substance	CAS No,
1,1,1,2-Tetrachlor-2,2-difluoroethane	76-11-9
1,1,1,3,3,3-Hexachlor-2,2-difluoropropane	3182-26-1
1,1,1,3,3-Pentachlor-2,2,3-trifluoropropane	2354-06-5
1,1,1,3-Tetrachlorotetrafluoropropane	2268-46-4
1,1,1-Tribromo-2,2,2-trifluoroethane	354-48-3
1,1,1-Trichloropentafluoropropane	4259-43-2
1,1,2-trichloro-1,2,2-trifluoroethane	76-13-1
1,1-Dibromo-1,2,2,2-tetrafluoroethane	27336-23-8
1,1-Dibromo-2,2-difluoroethylene	430-85-3
1,1-Dichlor-1,2,2,2-tetrafluoroethane	374-07-2
1,2,2-Trichloropentafluoropropane	1599-41-3
1,2,3-Trichloropentafluoropropane	76-17-5
1,2-Dibromo-1,1,2-trichloroethane	13749-38-7
1,2-Dibromo-1-chloro-1,2,2-trifluoroethane	354-51-8
1,2-Dibromotetrachloroethane	630-25-1
1,2-Dichloro-1,1,2,3,3,3-hexafluoropropane	661-97-2
1,2-Dichloro-1,1,3,3,3-pentafluoropropane	127564-92-5
1,2-Difluorotetrachloroethane	76-12-0
1-Bromo-1-chloro-2,2-difluoroethylene	758-24-7
2-Bromo-1,1-dichloroethylene	5870-61-1
Bromochlorodifluoromethane	353-59-3
Bromodichlorofluoromethane	353-58-2
Bromofluoromethane	373-52-4
Bromopentafluoroethane	354-55-2
Bromotrifluoroethylene	598-73-2
Bromotrifluoromethane	75-63-8
Carbon tetrabromide	558-13-4
Carbon tetrachloride	56-23-5
Chlorobromomethane	74-97-5
Chlorobromotrifluoroethane	74925-63-6
Chlorodibromomethane	124-48-1
chlorotrifluoroethylene	79-38-9

Chlorotrifluoromethane	75-72-9
Cryofluorane	76-14-2
Decafluorobutane	355-25-9
Dibromodichloromethane	594-18-3
Dibromodifluoromethane	75-61-6
Dibromotetrafluoroethane	25497-30-7
Dibromotetrafluoroethane (Halon 2402)	124-73-2
Dichlorodifluoromethane	75-71-8
dichlorotetrafluoroethane	1320-37-2
Ethane, 1-bromo-2-chloro-1,1,2-trifluoro-	354-06-3
Ethane, 2-bromo-1-chloro-1,1,2-trifluoro-	354-20-1
Ethane, 2-bromo-2-chloro-1,1,1-trifluoro-, (R)-	51230-17-2
Ethane, 2-bromo-2-chloro-1,1,1-trifluoro-, (S)-	51230-18-3
Ethane, tribromo-	598-16-3
Ethene, tetrabromo-	79-28-7
Heptachlorofluoropropane	135401-87-5
Heptachlorofluoropropane	422-78-6
Heptafluoropropyl chloride	422-86-6
Hexachlorodifluoropropane	134452-44-1
Hexachloroethane	67-72-1
Methane, bromotrichloro-	75-62-7
Methane, tribromofluoro-	353-54-8
Methyl bromide (Bromomethane)	74-83-9
Monochloropentafluoroethane	76-15-3
Octafluoropropane	76-19-7
Pentabromoethane	75-95-6
Pentachlorofluoroethane	354-56-3
Pentachlorotrifluoropropane	134237-31-3
Perfluoroethane	76-16-4
Tetrachlorotetrafluoropropane	29255-31-0
Tribromochloromethane	594-15-0
Trichlorofluoromethane	75-69-4
Trichlorotrifluoroethane	26523-64-8
Trichlorotrifluoroethane	354-58-5



The absence of above substances has not been verified by analysis or tests by LyondellBasell and is declared based on the information available to us from our raw material suppliers. The info we receive from our suppliers is info which they are legally obliged to share with their downstream users.

It can therefore not be excluded that trace levels of these substances may be unintentionally present (amongst others because they may be ubiquitous in the environment) or may result from the specific characteristics of the raw materials or the manufacturing process. It is the responsibility of the recipient of our products to ensure that any local applicable rules and legislation are observed.

---

## **Statement managed by LyondellBasell – Product Safety Department**

Issue date: September 22, 2020

Information in this document is accurate to the best of our knowledge at the date of publication. The document is designed to provide users general information for safe handling, use, processing, storage, transportation, disposal and release and does not constitute any warranty or quality specification, either express or implied, including any warranty of merchantability or fitness for any particular purpose. Users shall determine whether the product is suitable for their use and can be used safely and legally.

In addition to any prohibitions of use specifically noted in this document, LyondellBasell may further prohibit or restrict the sale of its products into certain applications. For further information, please contact a LyondellBasell representative or visit the LyondellBasell website at: <https://www.lyondellbasell.com/en/products-technology/product-safety-stewardship/>

The Trademark referenced within the product name is owned or used by the LyondellBasell family of companies.



## Food contact declaration - FDA

### Product

POLYBATCH CE 505 (117603)

This document is valid until the next relevant legislative, regulatory and /or compositional change.

### USA

The components of this product are compliant with the following FDA regulations on food contact: 21 CFR §175.105, 21 CFR §175.300, 21 CFR §175.300(b)(3)(iii), 21 CFR §175.320, 21 CFR §177.1520(c)2.1, 21 CFR §177.1520(c)3.1a, 21 CFR §177.2600, 21 CFR §178.2010, 21 CFR §181.28, 21 CFR §182.8994

The following limitations apply:

- According to 176.170 Table 1: All food types
- According to 176.170 Table 2: C - H

### Company contact

US: ASI-Amer.Regulatory.Requests@lyondellbasell.com

LATAM: ASI-ProductSafety.Latam@lyondellbasell.com

EU: ASI-productsafety.emea@lyondellbasell.com

APAC: ProductSafety.APAC@lyondellbasell.com

### Responsibility

Appropriate overall and specific migration tests on the final material or article will determine the regulatory suitability for contact with different food types and various end-use conditions, however, these are beyond the control of LyondellBasell and are a part of the responsibility of the user of this product.

### Statement managed by LyondellBasell – Product Safety Department

This document is created electronically and is valid without signature.

Date: 30/09/2020

Original text: English

Information in this document is accurate to the best of our knowledge at the date of publication. The document is designed to provide users general information for safe handling, use, processing, storage, transportation, disposal and release and does not constitute any warranty or quality specification, either express or implied, including any warranty of merchantability or fitness for any particular purpose. Users shall determine whether the product is suitable for their use and can be used safely and legally.

In addition to any prohibitions of use specifically noted in this document, LyondellBasell may further prohibit or restrict the sale of its products into certain applications. For further information, please contact a LyondellBasell representative or visit the LyondellBasell website at: <https://www.lyondellbasell.com/en/products-technology/product-safety-stewardship/>

The Trademark referenced within the product name is owned or used by the LyondellBasell family of companies.

Anna Wisniewska  
Gerresheimer Boleslawiec S.A.

PL -  
Poland

33808932

15.09.2020

---

## Declaration

---

### **CESA-slip PE 10227**

#### **Introduction**

This declaration applies exclusively to the above mentioned product when used as colouring or additive agent of a plastic food contact material and article. Our mixture is not intended to come directly in contact with food in its original form: therefore, since Clariant has no influence on subsequent processing, this declaration can not be extended to the finished material or article. Indeed, the compliance of the end material or article with the food contact regulations is the responsibility of the converter. He is committed to meet all relevant legal requirements and to test the migration limits according the conditions of use (temperature, time, simulants) of the article in its finished form (e.g. volume, geometry, thickness). These conditions are not part of our knowledge and therefore are not under Clariant's control.

#### **Framework Regulation (EC) No. 1935/2004 and GMP Regulation No 2023/2006**

Framework Regulation (EC) No. 1935/2004 sets out the general rules that must be met by all classes of food contact materials without giving any specific rule of how to prove the safety of food contact articles: plastic materials are covered by specific measures in relation to component types used in the formulation of our mixtures:

- polymers and additives are regulated by Regulation (EU) No 10/2011 and its amendments.
- colourants (including dyes, organic and inorganic pigments) must not migrate and must also comply with the purity requirements laid down in the national laws of Member States. General requirements for colourants are listed in the EU Resolution of the Council of Europe, AP (89) 1 though this is not legally binding.
- catalysts, solvents and polymer production aids (not yet listed at EU level) shall be assessed with general rules of the Framework Regulation by the substance manufacturer and/or shall comply with the national legislations provisions.

The product is not expected to cause any contravention to the Framework Regulation since the subsequent stages of manufacture, processing and distribution of the end article are in line with the Good Manufacturing Practices (GMP) applicable to food contact materials and article's supply chain, as listed in Regulation (EC) No 2023/2006. In addition, we would declare that our own production process, as a part of this supply chain will conform to the provisions of GMP.

*Hereafter the status of the different component types is given according to their applicable legislation and based on the declarations received by Clariant from starting materials suppliers:*

#### **Commission Regulation (EU) No 10/2011 and its amendments**

All the carriers and the intentionally added additives comply with the requirements of Regulation (EU) No 10/2011 and its amendments published before the release date of this certificate. We would like to remind you that the assessment of overall migration limit, other release restrictions such as those found in Annex II (the release of aromatic amines in a detectable quantity and the specific migration limits for all metals, especially considering low migration limits established) is the responsibility of the producer of the finished article

(converter).

## Restrictions and Limitations

- Octadecyl 3-(3,5-di-tert-butyl-4-hydroxyphenyl)propionate: SML = 6 mg/kg. Consider correction of specific migration in foods containing more than 20% fat by the fat reduction factor.

## Additional information

The formulation does not contain dual-use additives as referred to in Article 11(3) of Commission Regulation (EU) No 10/2011. We remind you that who produces the material or the article intended to be in contact with food must fulfil the restrictions listed in Annex II.

SML	Specific Migration Limit	SML(T)	Specific Migration Limit expressed as Total
DL/LR/NG	Detection Limit	FP/PF/BG	Finished Product or Article

## European Resolution AP (89) 1

The current formulation does not contain any component subject to this Resolution.

## Belgium: Arrêté Royal from 11.05.1992 of the Moniteur Belge 24.07.1992

The current formulation does not contain any component subject to this regulation.

## France: Jorf

The current formulation does not contain any component subject to this regulation.

## Germany: BfR Recommendation IX

The current formulation does not contain any component subject to the Recommendation IX.

## Italy: Decreto Ministeriale

The current formulation does not contain any component subject to this regulation.

## The Netherlands: Warenwet

The current formulation does not contain any component subject to this regulation.

## Spain: Real Decreto 847/2011 (subsecretaria para Sanidad)

The current formulation does not contain any component subject to this regulation.

## Turkey: Food Codex Regulation

All the components used meet the requirements of Turkish Food Codex Regulation on Materials and Articles in Contact with Foodstuffs issued in April 5th, 2018 and its amendments.

*We would also like to inform you of the status of our product in regard to the Directive 94/62/EC, CONEG (Regulation status and the content of diarylide pigments):*

## Directive 94/62/EC, CONEG and Heavy Metals

Heavy metals and/or their compounds are not intentionally added by us during production and, on the base of our present knowledge, they are not contained (or are present just as impurity at trace-level) in raw materials which are used for the production of above-mentioned product. In any case, our company does not carry out any specific analysis in order to detect the presence of above mentioned substances and then this statement is based

on specific information provided by our raw material suppliers. The product meets the requirements of the EC Directive 94/62/EEC and the CONEG regulation which limits the content of heavy metals up to 100 ppm (Cd, Pb, Hg, Cr(VI)).

## Diarylide Pigments

The product does not contain any intentionally added diarylide pigment in its chemical composition.

## Clariant Plastics & Coatings (Nordic) AB

### Country Product Stewardship

This declaration was produced automatically and therefore does not have an original signature.

This information corresponds to the present state of our knowledge and is intended as a general description of our products and their possible applications. Clariant makes no warranties, express or implied, as to the information's accuracy, adequacy, sufficiency or freedom from defect and assumes no liability in connection with any use of this information. Any user of this product is responsible for determining the suitability of Clariant's products for its particular application. Nothing included in this information waives any of Clariant's General Terms and Conditions of Sale, which control unless it agrees otherwise in writing. Any existing intellectual/industrial property rights must be observed. Due to possible changes in our products and applicable national and international regulations and laws, the status of our products could change. Safety Data Sheets providing safety precautions, that should be observed when handling or storing Clariant products, are available upon request and are provided in compliance with applicable law. You should obtain and review the applicable Safety Data Sheet information before handling any of these products. For additional information, please contact Clariant.

\* For sales to customers located within the United States and Canada the following applies in addition:

NO EXPRESS OR IMPLIED WARRANTY IS MADE OF THE MERCHANTABILITY, SUITABILITY, FITNESS FOR A PARTICULAR PURPOSE OR OTHERWISE OF ANY PRODUCT OR SERVICE.  
9/2010

**Anna Wisniewska**  
**Gerresheimer Boleslawiec S.A.**

**PL -**  
**Poland**

33808933

Version : 2 - 0

15.09.2020

---

## Declaration

---

**CESA-slip PE 10227**  
**Material number: PEA1175031**

### **Introduction**

This document is intended to provide information on the current status of the above-referenced material under certain regulatory programs. Please review this document carefully and contact your Clariant representative if you have any questions.

All statements refer exclusively to the named product in its current formulation: they are based on the present state of our knowledge and experience and concern the product in its original form and packaging as supplied from our factory.

Since the masterbatch and compound manufacturer has no influence on subsequent processing, the processor himself is responsible for ensuring that the finished article is suitable for the intended use, and is also responsible for ascertaining the compliance of the end article with the national and international regulations and laws concerning its application field. Due to the broad range of possible applications we make no warranty that the actual use of the product in the finished article is comprised by the information below.

*Hereafter the status of the different component types is given according to their applicable legislation and based on the declarations received by Clariant from starting materials suppliers:*

### **USA Food and Drug Administration**

In the USA substances used as a component of articles intended to come into contact with food are regulated by Food and Drug Administration FDA 21 CFR Title 21. Specific limitations and conditions of use, as set forth in these regulations, are specified below.

The components entering into the formulation of the above-referenced product are approved under one or more of the specific FDA paragraphs or have other clearances listed below:

1. Colorants listed in 21 CFR 178.3297 "Colorants for Polymers."

33808933, SubID: 000000326847, Mat#: PEA1175031

Page 1/3

The reproduction, entirely or partially, of this declaration or any deductive reasoning derived from it is not under Clariant's responsibility. The validity of these statements is twelve months.

2. Components that are exempt from regulation under 21 CFR 170.39, "Threshold of Regulation for Substances Used in Food Contact Articles."
3. Polymers and/or additives listed in the appropriate parts of 21 CFR (174, 175, 176, 177, 178, 181, 182, 184 and 186).
4. Substances that, based upon legal opinion, supplier certification, and/or extraction results from food-simulating solvents, are not food additives and are acceptable for food contact applications in full compliance with the Federal Food, Drug and Cosmetic Act and all applicable food additive regulations.
5. Substances that are GRAS (Generally Recognized as Safe) for direct addition to food or for use in contact with food.
6. Substances that are "Prior Sanctioned" for use in this application.
7. Substances that are the subject of applicable Food Contact Substance Notifications.

### **Condition of Use and Restriction:**

The finished articles are to contact food only under conditions of use B through H described in Table 2 of §176.170(c) of 21CFR.

### **Directive 94/62/EC and CONEG**

Based on the knowledge of the raw materials as well as of the manufacturing process this product meets the requirements of the Directive 94/62/EC and the CONEG regulation which limits the content of heavy metals up to 100 ppm (Cd, Pb, Hg, Cr(VI)).

### **Diarylide Pigments**

The product does not contain any intentionally added diarylide pigment in its chemical composition.

## **Clariant Plastics & Coatings (Nordic) AB**

### **Country Product Stewardship**

This declaration was produced automatically and therefore does not have an original signature.

This information corresponds to the present state of our knowledge and is intended as a general description of our products and their possible applications. Clariant makes no warranties, express or implied, as to the information's accuracy, adequacy, sufficiency or freedom from defect and assumes no liability in connection with any use of this information. Any user of this product is responsible for determining the suitability of Clariant's products for its particular application. Nothing included in this information waives any of Clariant's General Terms and Conditions of Sale, which control unless it agrees otherwise in writing. Any existing intellectual/industrial property rights must be observed. Due to possible changes in our products and applicable national and international regulations and laws, the status of our products could change. Safety Data Sheets providing safety precautions, that should be observed when handling or storing Clariant products, are available upon request and are provided in compliance with applicable law. You should obtain and review the applicable Safety Data Sheet information before handling any of these products. For additional information, please contact Clariant.

\* For sales to customers located within the United States and Canada the following applies in addition:

NO EXPRESS OR IMPLIED WARRANTY IS MADE OF THE MERCHANTABILITY, SUITABILITY, FITNESS FOR A PARTICULAR PURPOSE OR OTHERWISE OF ANY PRODUCT OR SERVICE.

9/2010

Anna Wisniewska  
Gerresheimer Boleslawiec S.A.

PL -  
Poland

33808931

15.09.2020

---

## Declaration

---

### **CESA-slip PE 10227**

#### **Introduction**

All statements refer exclusively to the named product in its current formulation: they are based on the present state of our knowledge and experience and concern the product in its original form and packaging as supplied from our factory.

Since the masterbatch and compound manufacturer has no influence on subsequent processing, the processor himself is responsible for ensuring that the finished article is suitable for the intended use, and is also responsible for ascertaining the compliance of the end article with the national and international regulations and laws concerning its application field.

#### **Additional information**

- Based on the current formulation of the above mentioned product, the following substances have not been intentionally added during its production:

BPA  
Latex  
Phthalates  
Melamine  
Allergens  
Nitrosamines

These substances were not used as starting materials during the mixing phase of our product but, on the basis of our current knowledge, we cannot give you any warranty they are not constitutionally contained (or are present at level of ubiquitous(\*\*) traces) in raw materials. Please note that, in any case our Company does not carry out any specific analysis in order to detect the presence of above mentioned substances.

(\*\*)Ubiquitous in regard to a chemical substance means that this substance is omnipresent (occurs literally everywhere) and its occurrence in this "ubiquitous" traces cannot be avoided by any technical, physical or chemical measure.

#### **Additional information**

In addition be informed that, in case here above was not clearly mentioned, you can find the following information into the Safety Data Sheet you already got by us:

- the ingredients that may be classified as dangerous for health and environment;

- information on restriction on use that we are aware of and that could be relevant for plastic applications.

## Clariant Plastics & Coatings (Nordic) AB

### Country Product Stewardship

This declaration was produced automatically and therefore does not have an original signature

This information corresponds to the present state of our knowledge and is intended as a general description of our products and their possible applications. Clariant makes no warranties, express or implied, as to the information's accuracy, adequacy, sufficiency or freedom from defect and assumes no liability in connection with any use of this information. Any user of this product is responsible for determining the suitability of Clariant's products for its particular application. Nothing included in this information waives any of Clariant's General Terms and Conditions of Sale, which control unless it agrees otherwise in writing. Any existing intellectual/industrial property rights must be observed. Due to possible changes in our products and applicable national and international regulations and laws, the status of our products could change. Material Safety Data Sheets providing safety precautions, that should be observed when handling or storing Clariant products, are available upon request and are provided in compliance with applicable law. You should obtain and review the applicable Material Safety Data Sheet information before handling any of these products. For additional information, please contact Clariant.

\* For sales to customers located within the United States and Canada the following applies in addition:  
NO EXPRESS OR IMPLIED WARRANTY IS MADE OF THE MERCHANTABILITY, SUITABILITY, FITNESS FOR A PARTICULAR PURPOSE OR OTHERWISE OF ANY PRODUCT OR SERVICE.

9/2010

---

## Declaration

---

CESA-slip PE 10227 (PEA1175031)

### Introduction

All statements refer exclusively to the named product and its current formulation as supplied from our factory in its original form and packaging and are based on the present state of our knowledge and experience.

Since the masterbatch manufacturer has no influence on subsequent processing, the processor himself is responsible for ensuring that the finished article is suitable for the intended use and to ascertain the compliance of the end article with the national and international regulations and laws concerning its application field.

### BSE/TSE:

Based on the knowledge of the raw materials as well as of the manufacturing process, we are able to confirm that the product does not contain intentionally added components of animal origin. They are not used by us during production and, on the base of our present knowledge, are not contained (or are present just as impurities at trace-level) in raw materials which are used for the production of our preparations; please note that in any case, our Company does not carry-out any specific analyses in order to detect the presence of the a.m. substances.

Clariant Plastics & Coatings (Nordic) AB  
Box 9053  
SE-200 39 Malmö  
Phone: +46 40 671 72 00  
E-mail: psmalmo@clariant.com  
Web: www.clariant.com



The attached declaration has been compiled according the best information available to us, and according to the laws in force at the publication date of the document itself. It is forbidden to, entirely or partially, reproduce the present declaration and to issue it to a third party without written assent of Clariant.

**Additional Information**

The information given in the present declaration is based on the current level of our knowledge, and is intended to provide information about our products. It should therefore not be construed as guaranteeing specific properties. Buyer or user are responsible for ensuring that the products they use, as supplied by us, comply with the specific requirements of their intended application.

Due to the progress (evolution) of national and international regulations and laws the status of the above mentioned product could eventually change. If you have any doubt relating to the current correctness of this declaration, please contact us for an update.

**Clariant Plastics & Coatings (Nordic) AB**

**Tine Tornqvist Tosun**  
**Product Stewardship**

This declaration was produced automatically, and therefore does not have an original signature

Clariant Plastics & Coatings (Nordic) AB  
Box 9053  
SE-200 39 Malmö  
Phone: +46 40 671 72 00  
E-mail: psmalmo@clariant.com  
Web: www.clariant.com



The attached declaration has been compiled according the best information available to us, and according to the laws in force at the publication date of the document itself. It is forbidden to, entirely or partially, reproduce the present declaration and to issue it to a third party without written assent of Clariant.

# Quality Control

The quality assurance system of Primary Packaging Plastics is oriented towards a “zero defect strategy”. AQL values for dimensions must be within agreed specified limits. The necessary safety with respect to avoidance of dimensions out of specification (OOS) is achieved by means of process validation including risk analysis and/or in-line measurements and/or measurements on samples.

AQL values are defined on attributive characteristics according to below classification.

## Classification of defects

Classification of defect	Effects of defects	Defect class	AQL		Consequence
			Containers / Caps		
Critical	<p>Critical defects are defects whose presence can have critical consequences. They can, for example:</p> <ul style="list-style-type: none"> <li>• endanger human life or health</li> <li>• or violate legal requirements</li> <li>• or lead to destruction or alteration of filling material</li> <li>• or seriously impair the reliability of storage</li> <li>• or seriously impair the efficiency of production tools, filling and packaging equipment</li> </ul>	1	(*)	(*)	Packaging material not usable
Major	<p>Major defects are defects whose presence can lead to considerable impairment. They can, for example:</p> <ul style="list-style-type: none"> <li>• lead to inefficient function and thus to deficiency of the packaging material/pack</li> <li>• or lead to consumer complaint</li> <li>• or lead to reduced efficiency in production</li> <li>• or impair the efficiency of production tools, and filling and packaging equipment</li> </ul>	2A	0.25	0.1	Usability of packaging material markedly impaired
		2B	1.0	0.4	Usability of packaging material moderately impaired
Minor	<p>Minor defects are defects whose presence do not have essential consequences, for instance they</p> <ul style="list-style-type: none"> <li>• represent a reduction in general quality</li> </ul>	3	4.0	2.5	Usability of packaging material slightly impaired

(\*) No AQL value is defined for defect class 1 since for this defect class, tests are done against zero defects with the greatest possible certainty and/or manufacturing process is to be correspondingly validated. The necessary safety with respect to the avoidance of critical defects class 1 is achieved by means of process validation measures including risk analysis and/or in-line inspection and system checks. If defects of class 1 are found, it must be determined whether the entire batch or part of the batch is affected.

If a partial quantity containing a critical, major or minor defect can be clearly and reliably separated, the quality of the remainder of the batch must be evaluated separately.

## AQL values for Duma Handy Cap

Defects	Defect class
<ul style="list-style-type: none"><li>- Raw material, primary packaging material or labelling not according to specification</li><li>- Mix-up</li><li>- CFU exceeds specification</li><li>- Shelf life exceeded</li><li>- Moisture vapour transmission or light transmission or single internal reflectance or physicochemical OOS according to USP (white products only)</li><li>- Migration testing exceeds requirements for food contact material (white products only)</li><li>- Contamination inside, contamination outside - can get into content</li><li>- Tears, clefts, holes, incompletely moulded - usability or tightness not ensured</li><li>- Defects on sealing points - tightness impaired</li><li>- Engraved/embossed text is missing or incorrect</li><li>- Threads from injection point - can be detached</li><li>- More than half of the tear band is torn off</li></ul>	1
<ul style="list-style-type: none"><li>- Foreign bodies incorporated in the material</li><li>- Contamination outside on product - cannot get into product</li><li>- Inhomogeneous colour</li><li>- Deformation, incompletely moulded - usability markedly impaired</li><li>- Defects on sealing points - tightness not impaired</li><li>- Injection point too high</li><li>- Flashes - usability markedly impaired</li><li>- Uneven surface</li><li>- Burn marks &gt; 2 mm</li><li>- PE - Bags with holes or incorrectly closed</li></ul>	2A
<ul style="list-style-type: none"><li>- Flashes – usability moderately impaired</li><li>- Burn marks ≤ 2 mm</li><li>- Notches and clefts and roughness</li><li>- Threads from injection point - cannot be detached</li></ul>	2B

*If a carton is damaged or soiled upon arrival, the error must be noted at arrival on the shipping documents and the carton discarded. The remaining part of the batch is to be received as normal goods.*

## Quality control for Duma Handy Cap

Activity	Control
Incoming control of raw materials	Identification of goods received and control of certificates.
Set-up new mould or change of raw materials or control specification	<b>Line clearance</b> including control of correct use of raw materials. One sample of each cavity produced at the same time is visually controlled by production and QC prior to production start.
Production	<p>QC operator performs a <b>visual control</b> of the products in accordance with ISO 2859-1. The samples are taken every second hour (one sample per cavity produced at the same time).</p> <p>New approval by production and QC is required after <b>machine stops</b> lasting more than one hour.</p> <p>In case of unplanned machine stops where products can be defected the products are 100% controlled or scrapped.</p> <p>If defects are detected, products are quarantine stored or 100% controlled.</p>
Quality control	<p>QC <b>reviews all the production documentation</b> and point out products that need additional control. This also includes follow-up on products which are quarantine stored by production.</p> <p>QC performs a <b>function test</b> on samples from two of the in-process controls by mounting, open and re-closing the system. The samples are from two different shifts.</p> <p>QC controls the pallets for mix-up and incorrect labeling, releases the products and issue certificates with the results of the controls.</p>

# Declaration of Conformity

## European Pharmacopoeia (EP)

Declaration concerns all products with the following composition:

- **LD653 & Colored & Slip agent**
- **LD653 & Colored & Slip agent & Silica gel & Bottom Foil**

Based upon certificates from our suppliers of masterbatches, Slip Agent, Silica Gel and Bottom Foil, Gerresheimer Vaerloese A/S hereby confirms that the above mentioned raw materials used during production comply with the relevant regulations related to plastic materials intended to come into contact with food however the suppliers do not declare the materials to be in compliance with the European Pharmacopoeia.

Gerresheimer Vaerloese A/S additionally informs that our packages dedicated for solid oral dosage forms and solid active substances are tested in accordance with food law. For such substances, it has been agreed by the Joint Committee for Medicinal Products for Human Use / Committee for Medicinal Products for Veterinary Use Quality Working Party that plastic materials compliant with the relevant European Union (EU) food legislation relating to plastic materials and articles intended to come into contact with foodstuffs are considered acceptable.

Yours sincerely,



Marta Slocka-Momotiuk

Compliance Specialist

Primary Packaging Plastics

# Declaration of Conformity

## European Union (EU) Food Contact

Based upon the certificates from the suppliers of the resins and/or masterbatches, Gerresheimer Vaerloese A/S hereby confirms that raw materials used in production of below mentioned products:

- Dudek Cap colored,
- Duma Handy Cap colored,
- Duma Handy Cap with Integrated Desiccant colored,
- Duma MG Cap colored,
- Duma Multi Grip Cap colored,
- Duma Special Container colored,
- Duma Standard Container colored,
- Duma Twist-Off with Desiccant, colored,
- Duma Twist-Off Cap colored,
- Duma Pocket colored,
- Duma Pocket Base colored,
- Duma MG Container colored

Comply with relevant requirements of Regulation 1935/2004/EC on materials and articles intended to come into contact with food (Framework Regulation); Regulation 2023/2006/EC on good manufacturing practice for materials and articles intended to come into contact with food (GMP) and Regulation 10/2011/EC (PIM) on plastic materials and articles intended to come into contact with food.

Yours sincerely,



Marta Slocka-Momotiuk  
Compliance Specialist

Primary Packaging Plastics

April 27, 2021

## Declaration of Conformity

Primary Packaging Plastics requires from all raw materials suppliers to inform about any animal derived substances used for production of their products and also requests from suppliers to consider and fulfill the relevant regulations of the European Community about the avoidance of TSE/BSE contamination.

If applicable, all suppliers are requested to fulfil the requirements:

- The animal derived substances used for the manufacturing of their polymers are either produced from animals originating from BSE-free countries or are free from SRM (specified Risk Material).
- The manufacture of the animal derived substances involves rigorous processes that meet/exceed the very severe process conditions for inactivating any BSE/TSE agent.

If any of raw materials contain ancillary materials based on fatty acid, such fatty acids might have a number of origins from for example plants, animal or synthetic, where the animal origin is the most common. The use of these subsidiaries as ancillary materials, including packaging for the pharmaceutical-and the foodstuff industries, are regulated through a number of EU directives. Tallow derived materials used in some product fulfill the requirements laid down in the Regulations 1069/2009/EC, and 142/2011/EC, and the "Note for Guidance EMEA/410/01, rev. 3". These directives regulate the general use of these products and specifically security against BSE to transmit to pharmaceutical-or foodstuff products.

Primary Packaging Plastics has received statements or certificates from all suppliers, where they state that:

- their products do not contain specific material of risk (SRM) and that infection does not transmit via their products, or
- their products fulfilled all requirements laid down in relevant regulations concerning BSE/TSE substances.

Yours sincerely,



Marta Słocka-Momotiuk  
Compliance Specialist  
Primary Packaging Plastics

April 14, 2020

## Declaration of Conformity

Primary Packaging Plastics only process raw materials delivered from suppliers and does not add any additional materials to such raw materials. Based upon certificates from raw materials suppliers, Primary Packaging Plastics hereby confirms that:

- Allergens
- Latex
- Melamine
- Bisphenol A
- Phthalates

have not been intentionally added during their production. However, the fact that these substances are not used in these products does not exclude that trace levels of them may be present as a result of the specific characteristics of raw materials and/or of the manufacturing process. Please note that, in any case suppliers do not carry out any specific analyses in order to detect the presence of above mentioned substances.

The information is given to the best of our knowledge and does not include any warranty whatsoever. It must therefore not be misunderstood as guaranteeing specific properties. End-customers have to decide at their own discretion about the suitability of our products for their purposes, based on the explicit descriptions in our product specifications.

Yours sincerely,



Katarzyna Jawor  
Compliance Specialist  
Primary Packaging Plastics

# DECLARATION OF CONFORMITY

**Gerresheimer Vaerloese A/S  
Walgerholm 2-8  
3500 Værløse, Denmark**

Gerresheimer Vaerloese A/S has taken appropriate precautions to reduce the risk for TBA (2,4,6-tribromoanisole) and TCA (2,4,6-trichloroanisole) contamination of products supplied to our customers.

TBA with a threshold of 0.02 PPT and TCA with a threshold of 1 PPT do not introduce any toxicological risks but can have impact in musty molded odor.

Risk for TBA/TCA contamination is included into the risk analysis for the whole manufacturing and handling/storage process in the plant and all wooden pallets used for raw materials, component and final products are heat treated and comply with ISPM 15.

Gerresheimer Vaerloese A/S can only be held responsible for any odor issues due to TBA and/or TCA contamination, if it can be proven that the contamination of the primary plastic packaging has happened before shipment of the products.

Værløse, April 16<sup>th</sup>, 2020



Christina D. Holder  
Quality Manager

# Customer Complaint Report

<input type="checkbox"/> Complaint <input type="checkbox"/> Comment / Remark  Customer report No:	Established by / date:
Customer name / address / country:	Contact person / E-mail / Fax no.:
Article no.:	Date of delivery:
Batch no.:	Invoice no.:
Cavity no.:	Order no.:
Number of defective items:	Total quantity delivered:
Defect observed in: <input type="checkbox"/> Incoming control.....    Sample size: <input type="checkbox"/> Production.....    Quantity of items used: <input type="checkbox"/> Final product(s).....    Quantity of items used: <input type="checkbox"/> Complaint from end-user	
Defect found in: <input type="checkbox"/> One carton <input type="checkbox"/> Several cartons: Quantity _____	Exact production date/time from carton/bag or carton/bag/pallet number:  <input type="checkbox"/> Not available
Are filled/not filled products quarantined: <input type="checkbox"/> Yes – Quantity (filled): <input type="checkbox"/> Yes – Quantity (not filled): <input type="checkbox"/> No <input type="checkbox"/> N/A – no products left	Samples: <input type="checkbox"/> Will be sent <input type="checkbox"/> Not available <input type="checkbox"/> Additional information will be forwarded
Description of defect:	

Received by QA dept. (init. / date): \_\_\_\_\_

## Information requested in relation to complaint investigation

We will kindly ask you to supply us with the answers to the below listed questions. The information is important for us, to make a thorough investigation.

Please return the information as soon as possible, so that we can initiate our investigation.

### Labelling

Company name:	Today's date:
<input type="checkbox"/> Wrong information <input type="checkbox"/> Missing information <input type="checkbox"/> Missing label <input type="checkbox"/> Label difficult to read	
<input type="checkbox"/> Samples have been send <input type="checkbox"/> Samples will be send <input type="checkbox"/> Pictures are available <input type="checkbox"/> No samples or pictures are available	
The defect is observed in <input type="checkbox"/> One bag/carton <input type="checkbox"/> Several bags/cartons - Quantity	
Exact production date and time for all concerned bags	
Exact quantity of defective items/bags/cartons	
How many bags/cartons have been controlled	
Amount of products blocked	
Comments:	

## Information requested in relation to complaint investigation

We will kindly ask you to supply us with the answers to the below listed questions. The information is important for us, to make a thorough investigation.

Please return the information as soon as possible, so that we can initiate our investigation.

### Loose silica gel / loose desiccant / defect on desiccant

Company name:	Today's date:
<input type="checkbox"/> Samples have been send <input type="checkbox"/> Samples will be send <input type="checkbox"/> Pictures are available <input type="checkbox"/> No samples or pictures are available	
Defect observed in: <input type="checkbox"/> Upon reception at your warehouse <input type="checkbox"/> Incoming inspection - sample size/plan: _____ <input type="checkbox"/> Observed in PDS <input type="checkbox"/> Before filling/when opening the cartons <input type="checkbox"/> Before filling/on your line <input type="checkbox"/> After filling <input type="checkbox"/> Market complaint	
Defect observed in <input type="checkbox"/> One bag <input type="checkbox"/> Several bags - Quantity	
Exact production date and time for all concerned bags	
Exact quantity of defective items	
Are there any signs of damage to cap, desiccant or cardboard	
Are there any signs of transport damage to bag or carton	
Quantity of item used or controlled from the batch	
Amount of products blocked	
Amount of filled products blocked	
Comments:	

## Information requested in relation to complaint investigation

We will kindly ask you to supply us with the answers to the below listed questions. The information is important for us, to make a thorough investigation.

Please return the information as soon as possible, so that we can initiate our investigation.

### Mix-up

Company name:		Today's date:	
Ordered product			
Product received			
How many bags/cartons have been controlled			
Amount of products blocked			
Production date and time of all the concerned bags/cartons			
<input type="checkbox"/> Samples have been send <input type="checkbox"/> Samples will be send <input type="checkbox"/> Pictures are available <input type="checkbox"/> No samples or pictures are available			
<p>For for mix-up - both carton label and bag label is important – and it would be helpful, if the pictures also showed the production date/time.</p>			
Comments:			

## Information requested in relation to complaint investigation

We will kindly ask you to supply us with the answers to the below listed questions. The information is important for us, to make a thorough investigation.

Please return the information as soon as possible, so that we can initiate our investigation.

### Partly- or disconnected TE-rings

Company name:	Today's date:
<input type="checkbox"/> Samples have been send <input type="checkbox"/> Samples will be send <input type="checkbox"/> Pictures are available <input type="checkbox"/> No samples or pictures are available	
Quantity of caps with disconnected TE-rings	
Quantity of caps with partly disconnected TE-rings <i>Please specify quantity of broken bridges according to the AQL values/specification.</i>	
Specific cavity number affected	
Defect observed in: <input type="checkbox"/> Incoming inspection - sample size/plan: _____ <input type="checkbox"/> Observed in PDS <input type="checkbox"/> Before filling/when opening the cartons <input type="checkbox"/> Before filling/on your line <input type="checkbox"/> After filling <input type="checkbox"/> Market complaint	
Quantity of item used or controlled from the batch	
Amount of products blocked	
Amount of filled products blocked	
Defect observed in <input type="checkbox"/> One bag/carton <input type="checkbox"/> Several bags/cartons - Quantity	
Exact production date and time for all concerned bags	
Are there signs of damage to the cap/bag/carton	
Comments:	

## Information requested in relation to complaint investigation

We will kindly ask you to supply us with the answers to the below listed questions. The information is important for us, to make a thorough investigation.

Please return the information as soon as possible, so that we can initiate our investigation.

### Product defect

Company name:	Today's date:
<input type="checkbox"/> Samples have been send <input type="checkbox"/> Samples will be send <input type="checkbox"/> Pictures are available <input type="checkbox"/> No samples or pictures are available	
Defect observed in: <input type="checkbox"/> Upon reception at your warehouse <input type="checkbox"/> Incoming inspection - sample size/plan: _____ <input type="checkbox"/> Observed in PDS <input type="checkbox"/> Before filling/when opening the cartons <input type="checkbox"/> Before filling/on your line <input type="checkbox"/> After filling <input type="checkbox"/> Market complaint	
Exact quantity of defective items	
Specific cavity number affected	
Quantity of item used or controlled from the batch	
Amount of products blocked	
Amount of filled products blocked	
Defect observed in <input type="checkbox"/> One bag <input type="checkbox"/> Several bags – Quantity	
Exact production date and time for all concerned bags	
Comments:	

## Information requested in relation to complaint investigation

We will kindly ask you to supply us with the answers to the below listed questions. The information is important for us, to make a thorough investigation.

Please return the information as soon as possible, so that we can initiate our investigation.

### Transport

Company name:	Today's date:
<input type="checkbox"/> Pictures are available <input type="checkbox"/> No pictures are available	
<input type="checkbox"/> A copy of the CMR ("Proof of delivery" from the transporter) has been forwarded <input type="checkbox"/> A copy of the CMR ("Proof of delivery" from the transporter) will be forwarded <input type="checkbox"/> The CMR ("Proof of delivery" from the transporter) is not available	
Defect observed on <input type="checkbox"/> One carton <input type="checkbox"/> Several cartons	
Exact quantity of damaged cartons	
Products can be used	<input type="checkbox"/> yes / <input type="checkbox"/> No
Comments:          	