	Printed, the document is not a controlled document.	Level:
	043050-0000 Duma Special	Approved by: ATL 10.05.2016
	Document owner: VriQM	Implementation: 10.05.2016
Version: 3.14	Document no.: 1.12.3.1	Standard Product Database
Document users:		

Product Specification and Certificate

Product no.	043050-0000
Product name	Duma Special 50 ml
Product description	45 mm round plastic container with a snap-on neck to be provided with Duma Handy Cap 4015. Index in the bottom. Intended for the packing of tablets and powder.
Design	B043050
Raw material	Purell PE GF 4760, High-density polyethylene (HDPE) in compliance with Regulation (EU) 10/2011 and FDA title 21 CFR § 177.1520, LyondellBasell Industries. Coloured with 3.0-4.5% white masterbatch, containing about 59% titanium dioxide. Purell GF4760 Declaration 2016
Colour	PE 22305+ Remafin-White, Low-density polyethylene (LDPE) in compliance with Regulation (EU) 10/2011, FDA title 21 CFR § 178.3297 and BfR recommendation IX, Clariant Plastics & Coatings (Italia) S.p.A. PE 22305+ Declaration
Production	Facility: Vaerloese, Denmark Process: The containers are injection blow moulded Hygiene: The production takes place in clean room Sterilisation: N/A

Measures and Properties

Dimensions:			
Container:		Neck:	
Outside height	51.0 +1.0/-1.0 mm	Inside diameter	33.0 +0.2/-0.2 mm
Outside diameter	45.0 +0.5/-0.5 mm	Upper outside diameter	39.6 +0.2/-0.3 mm
		Neck ring diameter	41.8 +0.3/-0.3 mm
Wall thickness	Min. 0.4 mm		
Other dimensions:			
Label height	Max. 32 mm	Volume	Max. 69 ml
Label width	Max. 141 mm	Shelf life	5 years
Weight	7.3 +0.5/-0.4 gr	Bioburden	Max. 50 CFU

Test Results

<p>The container and cap comply with all demands for Water Vapour Permeability and Light Transmission and are in accordance with USP. Documentation enclosed.</p> <p>WVP - 043050-0000/004015-2000/JUN2014 LT - 043050-0000/MAR2013</p>

The container and cap comply with all demands for Multiple Internal Reflectance and fulfil the conditions regarding Heavy Metals and Non-volatile Residue and are in accordance with USP. Documentation enclosed.

[IR - GF4760 / PE22305+](#)

[Migr. - GF4760/PE 22305+/JUN2012](#)

Packing and Way of Delivery

The products are packed in 1 LDPE bag, which is then heat-sealed. The LDPE bag is put into a cardboard carton, which is sealed with 2 PP-straps. The cartons are packed on pallets, which are 1200 x 800 x 140 mm and weight approximately 23 kg.

Carton dimensions:

Height (mm): 350 Length (mm): 780 Width (mm): 600

Packing information:

Number of items per carton: 1150 Volume per carton (m³): 0.163
Max. number of cartons per pallet: 12 Weight per carton (kg.): 9.9
Max. height of the pallet (mm): 2300

Labelling

Each carton is provided with a label with the following information:

Product name and no.

Quantity

Machine no.

Production date / Batch no.

The bags in the carton is also marked with date and machine no.

Recommendation to Storage, Handling and Transportation

Stored inside in clean conditions in its original un-open packaging, protected from direct sunlight and with a temperature between 5 - 35° C and Relative Humidity between 30 - 70 %.

Quality Control

All products are quality controlled according to instructions specified in our quality control system. We therefore guarantee that all deliveries from Gerresheimer Plastic Packaging have passed our control procedures and comply with the quality demands mentioned below. If required a certificate can be issued. The classification of defects and specifications of AQL values are based on ISO 2859 and Quality Assurance of Pharmaceutical and Cosmetic Packaging Materials:

Defect Evaluation List for Plastic Blow-moulded containers Vol. 23 - ISBN 3-87193-159-4.

Defect Evaluation List for Injection-moulded parts made of Plastic: Closures, Sealing Disks and dosage aids (droppers, etc.) Vol. 22 - ISBN 3-87193-182-9.

Documentation enclosed.

[Quality Control - IBM Containers - Vaerloese](#)

Declaration of Conformity

Based upon the certificates from our suppliers of raw material and masterbatch, product tests based on the European Pharmacopeia and/or US Pharmacopeia and our certified Quality system, we hereby confirm that our products comply with the European Pharmacopeia current edition, Paragraph 3.2.2 "Plastic containers and closures for pharmaceutical use".

Information on Packaging and Packaging Waste Directive 94/62/EC

Both container, cap and bag are produced from material, which complies with the directions for plastics material in contact with foodstuffs. The content of heavy metals in the products, the inner bag, and the carton is less than 100 ppm.

The products can be utilised by recovery of material and because of a high heating value by recovery of energy.

REACH

We can confirm that the raw materials used in the product are either pre-registered or exempted from pre-registration.

BSE/TSE

The supplier of Masterbatch (Colour) has declared that the material does not include substances of animal origin.

In the raw material we are using ancillary materials based on fatty acid. These fatty acids might have a number of origins from for example plants, animal or synthetic, where the animal origin is the most common. The use of these subsidiaries as ancillary materials, including packaging for the pharmaceutical- and the foodstuff industries, are regulated through a number of EU directives. These directives regulate the general use of these products and specifically security against BSE to transmit to pharmaceutical- or foodstuff products.

All suppliers are requested to fulfil the requirements:

The animal derived substances used for the manufacturing of these polymers are either produced from animals originating from BSE-free countries or are free from SRM (specified Risk Material).

The manufacture of the animal derived substances involves rigorous processes that meet/exceed the very severe process conditions for inactivating any BSE/TSE agent.

We have received a statement or a certificate from the suppliers where they state that their products do not contain specific material of risk (SRM) and that infection does not transmit via their products.

Registrations and Certifications

Gerresheimer Plastic Packaging was established in January 2006. Before that time the company was working under the following names: Superfos Pharma, Superfos Pharma Pack, Dudek Plast and Duma.

Documentation, i.e. test reports, certificates etc. issued before January 2006 will be with reference to one of the names above.

Gerresheimer Vaerloese A/S has obtained the following registrations and certifications for Vaerloese and Haarby, Denmark:

ISO 9001, no. 160454-2014-AQ-DEN-DANAK

ISO 14001, no. 156579-2014-AE-DEN-DANAK

ISO 15378, no. 160455-2014-Q-DEN-DNV

The product is FDA registered in US with the following DMF number:

DMF 12077 – DMF type III Packaging material, Manufactured in Vaerloese - Denmark, Haarby - Denmark.

The product is TPD registered in Canada with the following DMF number:

DMF 2000-108 - Packaging material –Drug Master File. Packaging material, Manufactured in Vaerloese - Denmark, Haarby- Denmark.

The product is SFDA registered in China with the following license number:

J20050032 - Duma Twist-Off.

The product is registered in Russia with the following number:

C3 2011/11203 – plastic packages in size between 3ml to 3000 ml with accessories.

The product is registered in Ukraine with one of the following numbers:

10787/2011

10785/2011

10786/2011
14788/2015
14789/2015

Revisions

Version:	Implementation:	Revision information:
1	08.02.2010	Transfer to new system, additional information and change in dimensions/tolerances of inside diameter, upper outside diameter and neck ring diameter
2.1	23.11.2010	Updated GF 4760 declaration, weight per carton changed from 10.5 to 11.0 and recorection of version number from 1.0 to 2.1
2.2	13.07.2011	GF 4760 Declaration 2011: Updated GF4760 declaration GF 4760: Updated Regulation (EU) 10/2011 Clariant PE 22305+: Updated with Regulation (EU) 10/2011
2.3	14.07.2011	PE22305 Declaration 2011
2.4	19.09.2011	Number of items per carton reduced from 1300 to 1150. Weight per carton reduced from 11.0 to 9.9
2.5	31.01.2012	Registrations and Certifications: More precise description of registrations
2.6	15.03.2012	GF 4760 Declaration 2012: Updated
2.7	29.05.2012	IR - GF4760 / PE22305+: Updated
2.8	09.08.2012	Purell PE GF 4760 declaration 2012: Updated
2.9	03.01.2013	PE 22305+ Declaration 2012: PE 22305+ declaration updated
2.10	28.02.2013	Migr. - GF4760/PE 22305+/JUN2012: Updated
3	08.04.2013	Coloured with 3.0-4.5% white masterbatch
3.1	08.04.2013	LT - 043050-0000/MAR2013: Updated
3.2	18.04.2013	PE 22305+ Declaration 2013: Updated
3.3	24.07.2013	IR - GF4760 / PE22305+: Updated
3.4	05.12.2013	Purell GF4760 Declaration 2013: Updated
3.5	13.01.2014	PE 22305+ Declaration 2013: Updated
3.6	25.02.2014	Purell GF4760 Declaration 2014: Updated
3.7	10.06.2014	PE 22305+ Declaration: Updated
3.8	18.06.2014	WVP - 043050-0000/004015-2000/JUN2014: Updated
3.9	09.07.2014	Purell GF4760 Declaration 2014: Updated
3.10	23.03.2015	Purell GF4760 Declaration 2015: Updated
3.11	17.09.2015	PE 22305+ Declaration: Updated
3.12	11.01.2016	Purell GF4760 Declaration 2016: New SVHC list - 17.12.2015
3.13	08.04.2016	Clariant PE 22305+: Clariant new company name
3.14	10.05.2016	Registrations and Certifications: Updated

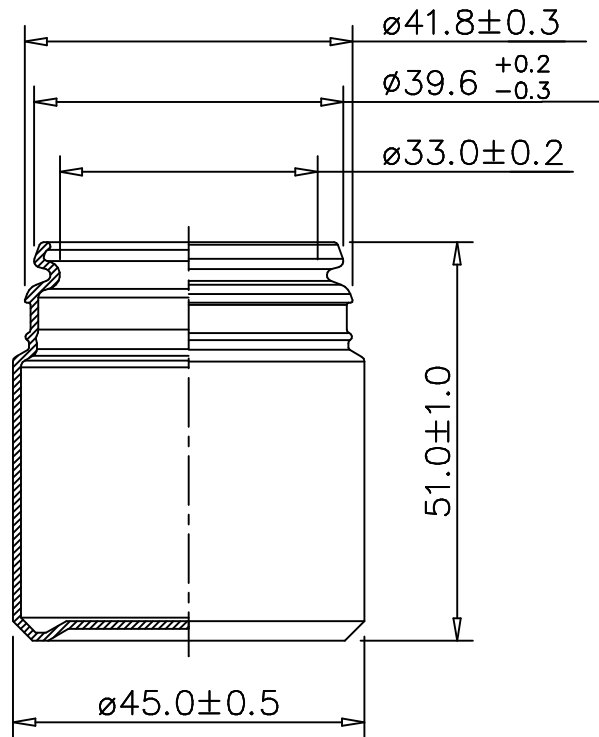
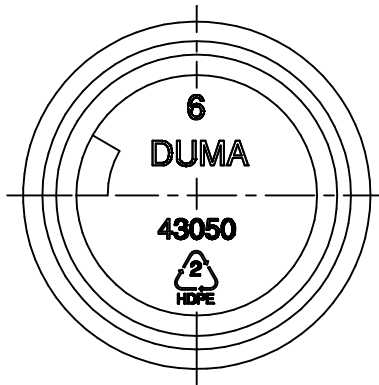

Tolerance changed	29.12.2009	MG	29.12.2009		GERRESHEIMER	Gerresheimer Vaerloese A/S Walgerholm 2-8, Postbox 229 DK-3500 Vaerloese	Phone +45 4477 7888 Fax. +45 4477 7892
Tolerance changed	25.09.2009	MG	25.09.2009				
Logo changed	19.06.2009	JJ	19.06.2009		This drawing may not be handed over, copied or used by others	Item	No. B043050
No. and logo changed	17.03.2006	JJ	17.03.2006				
Dimension erased	08.2005	JJ	08.2005		Duma Special 043050	50ml.	Vers. no.: 1
Dimension added	07.2004	JJ	07.2004				
Engraving added	04.2003	JJ	04.2003				
Created	05.2000	JJ	05.2000				
Created / Correction	Date	Sign.	Appr. Date	Sign.			

January 05, 2016

Anna
Gerresheimer Boleslawiec S.A.
ul. Boleslawa Chrobrego 15
59-700 Boleslawiec
Poland



Purell PE GF4760

A product of Basell Sales & Marketing Company B.V.

Dear Anna:

The following is in response to your request for Product Stewardship Information (PSInfo) for the product listed above. The attached Product Stewardship Bulletin (PSB) details the regulatory status of this product.

LyondellBasell Industries responds to product stewardship requests with a standardized Product Stewardship Bulletin (PSB) which summarizes the global regulatory status of a product. LyondellBasell Industries will not complete customers' forms or questionnaires. Standardized responses provide each customer with consistent information in a timely fashion. Each request is reviewed to ensure our response documents provide relevant information.

Please note that compliance with these regulations should not be interpreted to guarantee that the product, will, in fact, perform in a particular application. Your Technical Service Representative can help you determine that the characteristics of the product are compatible with the desired conditions of use.

Should you have any further questions concerning a LyondellBasell product, or if we can assist in any other way, please do not hesitate to contact us.

Best regards,

A handwritten signature in grey ink, appearing to read 'M. Poltronieri'.

Micaela Poltronieri
Product Safety Specialist
+39 0532 46 8087
micaela.poltronieri@lyondellbasell.com

Product Stewardship Bulletin



Purell PE GF4760

A product of Basell Sales & Marketing Company B.V.

Global Food Contact Status:

European Union

This product complies with the relevant requirements of Regulation 1935/2004/EC (Framework Regulation) as applicable to intermediate materials (e.g. plastic powders, plastic granules or plastic flakes).

This product complies with the relevant requirements of Regulation 2023/2006/EC (GMP) and as amended, applicable to intermediate materials (e.g. plastic powders, plastic granules or plastic flakes).

This product complies with the relevant requirements of Regulation 10/2011/EC (PIM) as amended, applicable to intermediate materials (e.g. plastic powders, plastic granules or plastic flakes).

The monomers and additives used to produce this product are listed in the Union List of Authorized Substances of Regulation 10/2011/EC and subsequent amendments.

EU Regulation 10/2011/EC specifies 10 mg/dm² as the maximum overall migration (OML) from the finished plastic food contact material or article. The OML and SMLs (when applicable) should be determined according to the requirements specified in EU Regulation 10/2011/EC and subsequent amendments. The OML and SML determinations are the responsibility of the manufacturer of the finished plastic food contact material or article. In addition, we remind you that the manufacturers of the finished food contact material or article must verify that the finished material or article, manufactured according to good manufacturing practices, does not modify the organoleptic properties of the food.

SML Components

This product contains one or more components with Specific Migration Limits (SMLs).

93280; distearylthiodipropionate; SML(T) = 5 mg/kg (14).

68320; Octadecyl 3(3,5-Di-tert-butyl-4-hydroxyphenyl) propionate; SML = 6 mg/kg

This product contains one or more Dual Use Additives as defined in Regulation 10/2011/EC.

- ▶ E 470a Calcium salts of fatty acids

EU National Legislations

The composition of this product complies with the following National Legislations, Recommendations or Communications for the production of food packaging.

Austria: "K.V.O." N.476/2003 as amended at last by BGBl - Teil. II - N.140/2009

Belgium: "Arrete royal du 5 juillet 2006 (amending Arrete royal du 11 mai 1992 and modifying "Arrete royal du 3 juillet 2005").

Denmark: Bekendtgørelse N.579 (01/06/2011)

Finland: "KTM", Paatos 953/2002 of 12.11.2002 (amended by 107/2009 of 03/03/2009)

France: "Materiaux au contact des aliments et de denre destine a l'alimentation humaine" Brochure n.1227 edition Janvier 1994 as updated. Arrete du 02 Janvier 2003 (as modified at last by Arrete 03/09/2010).

Germany: Bedarfsgegenstaendeverordnung in der Fassung vom 23 Dezember 1997 (BGBl. I 1998 S.5), zuletzt geandert durch Art. 1 der Verordnung vom 24 Juni 2013 (BGBl I S. 1682)

Greece: AXE Decision n.458/2003 modified by Decision n. 6/2011

Ireland: S.I. No. 587 of 2007, as amended by S.I. No.301 of 2010

Italy: "Decreto Ministeriale del 21/03/1973" amended on 26/4/1993 : D.M. N.220 and following updates (last update: D.M. of 16/02/2011).

Luxembourg: "Reglement Grand-Ducal" n. 163 du 05/11/2008.

Norway: Regulations 21 December 1993, No. 1381, on materials and articles intended to come into contact with foostuffs Chapter I General regulations, as amended.

Portugal: Decreto-Lei No. 62/2008 of 31/03/2008, and Amend. Decreto-Lei No. 29/2009, of 02/02/2009.

Spain: Real Decreto N.118 31/01/2003, modified by Real Decreto N.103/2009, of 06/02/2009.

Sweden: Ordinance of the National Food Administration on materials and articles intended to come into contact with foodstuffs LIVSFS 2011:7.

The Netherlands: Staatscourant n.6861 of 06.05.2010.

England: "The Plastic Materials and Articles in Contact with Food (England) Regulations 2009", Statutory Instrument 2009 n. 205.

Switzerland: BGVO 817.023.21 of 23 November 2005, as amended.

Czech Republic: Regulation of the Ministry of Health N.551/2006, modifying N.38/2001.

United States

The base resin in this product meets the FDA requirements contained in the Code of Federal Regulations in 21 CFR 177.1520(a)(3)(i) and (c)3.2a.

This product may also contain adjuvant substances that may be safely used in polymers used for the manufacture of articles that come into direct contact with food. According to our information, the substances used in this product meet the requirements of their respective FDA regulations and 21 CFR 177.1520(b).

This product meets the FDA criteria in 21 CFR 177.1520 for food contact applications, including cooking, listed under conditions of use A through H in 21 CFR 176.170(c), Table 2, and can be used in contact with all food types as listed in 21 CFR 176.170(c), Table 1.

Allergen Statements

The food ingredients listed in Annex II of Regulation (EU) No 1169/2011, are not used in the manufacture of or formulation of this product. However, this product has not been tested for these substances.

Biomedical Policy

This product(s) may not be used in:

(i) any U.S. FDA Class I, Health Canada Class I, and/or European Union Class I Medical Devices, without prior notification to Seller for each specific product and application; or (ii) the manufacture of any of the following, without prior written approval by Seller for each specific product and application: (1) U.S. FDA Class II, Health Canada Class II or Class III, and/or European Union Class II Medical Devices; (2) film, overwrap and/or product packaging that is considered a part or component of one of the aforementioned Medical Devices; (3) packaging in direct contact with a pharmaceutical active ingredient and/or dosage form that is intended for inhalation, injection, intravenous, nasal, ophthalmic (eye), digestive, or topical (skin) administration; (4) tobacco related products and applications; (5) electronic cigarettes and similar devices.

(iii) Additionally, the product(s) may not be used in: (1) U.S. FDA Class III, Health Canada Class IV, and/or European Class III Medical Devices; (2) applications involving permanent implantation into the body; (3) life-sustaining medical applications.

All references to U.S. FDA, Health Canada, and European Union regulations include other country's equivalent regulatory classifications.

Users should review the applicable Safety Data Sheet before handling the product.

Animal Based Raw-Materials (BSE/TSE)

Tallow

Tallow derived additives may be used in the manufacture of this product.

Europe - BSE/TSE - "Mad Cow"

Tallow derived materials used in this product fulfill the requirements laid down in the Regulations 1069/2009/EC, and 142/2011/EC, and the "Note for Guidance EMEA/410/01, rev. 3".

Epoxy Derivatives

The materials BADGE, BFDGE or NOGE are not intentionally added in this product as referenced in Commission Regulation 1895/2005/EC, on the use of certain epoxy derivatives in materials and articles intended to come into contact with foodstuffs as plasticizers, additives or raw materials.

Conflict Minerals (Dodd-Frank Wall Street Reform and Consumer Protection Act - September, 2010)

Please see link below for the position of LyondellBasell concerning this Act:

<https://www.lyondellbasell.com/en/investors/corporate-governance/?id=52>

The link to this document is located in the right margin under the heading "Corporate Governance Documents" titled "Conflict Minerals Policy".

Genetically Modified Organisms (GMO)

Additives derived from Genetically Modified Organisms (GMO's) are not intentionally used in the formulation of this product.

Halal Certification

This product is not certified as Halal.

Kosher Certification

This product is not certified Kosher.

Latex

No materials containing latex or natural rubber are used in the manufacturing, handling and packaging processes for this product.

Medical

European Pharmacopeia (EP)

This product meets the EP requirements for 3.1.3, Polyolefins - 8th Edition of European Pharmacopeia.

ISO 10993

Biological reactivity evaluations have been performed on representative samples of this product, specifically the Chapter 88 USP Biological Reactivity Tests, In Vivo for a Class VI plastic (Systemic Injection Test, Intracutaneous Test, Implantation Test). These USP tests may fit the requirements of certain sections of 10993-10 (tests for irritation and skin sensitization) and 10993-11 (tests for systemic toxicity). Despite this, the manufacturer of a medical device made with this product must still evaluate the medical device to show that it fully meets the requirements of the applicable sections of ISO 10993.

Results provided by Seller are intended to be representative in nature only and are not to be construed as a guarantee of future product performance. Seller makes no express or implied warranty by virtue of disclosing pass/fail status.

US Pharmacopeia (USP)

Representative samples of this product have passed the Chapter 88; USP Biological Reactivity Tests, In Vivo for a Class VI plastic (Systemic Injection Test, Intracutaneous Test, Implantation Test). In addition, the Physico-chemical testing of this product met the USP limits defined in Chapter 661.

Results provided by Seller are intended to be representative in nature only and are not to be construed as a guarantee of future product performance. Seller makes no express or implied warranty by virtue of disclosing pass/fail status.

US FDA Drug Master File (DMF)

Information on this product is listed in DMF N. 5654. Contact LyondellBasell for a DMF authorization letter to be sent to FDA.

Metals Content

US CONEG

Based on the available documentation provided by our raw material suppliers, this product complies with the CONEG Model Legislation for requirements regarding the defined limit for the sum of heavy metals (lead, mercury, cadmium and hexavalent chromium).

EU Packaging and Packaging Waste

Based on the available documentation from raw materials suppliers, this product complies with the directive 94/62/EC and its following amendments concerning the defined limit(s) of heavy metals.

Restriction of Hazardous Substances in Electric and Electronic Equipment (RoHS)

RoHS Regulation refers to electrical and electronic equipment and not specifically to plastic raw materials. However, based on the available documentation from raw materials suppliers, this product complies with the requirements of the Directives 2002/95/EC, as amended, and 2011/65/EU concerning the limits of cadmium, lead, mercury, hexavalent chromium, polybrominated biphenyls (PBB) and polybrominated diphenyl ethers (PBDE).

Nanomaterials

Nanomaterials (defined as natural, incidental or manufactured materials containing particles, in an unbound state or as an aggregate or as an agglomerate and where, for 50 % or more of the particles in the number size distribution, one or more external dimensions is in the size range 1 nm - 100 nm) are not used in the manufacture of or the formulation of this grade. However, this product has not been tested for these chemical substances.

Other Chemicals

The chemical materials listed below are not used in the manufacture or the formulation of this product and are not expected to be present. However, this product has not been tested for these chemical materials.

2-(2H-1, 2, 3-Benzotriazol-2-yl)-4,6-di-tert-butylphenol; (Benzotriazole); CAS# 3846-71-7;

2,4,4'-trichloro-2'-hydroxydiphenyl ether; (Triclosan); CAS# 3380-34-5;

2-mercaptobenzothiazole; MBT; CAS# 149-30-4;

Acrolein; (propenal); (CAS# 107-02-8);

Acrylamide; CAS# 79-06-1;

Aromatic amines;

Asbestos;

Azo Dyes and Pigments;

Polyaromatic Hydrocarbons - PAHs:

1,2-dihydro-acenaphthene; (CAS# 83-32-9);

9H-Fluorene; (CAS# 86-73-7);

Acenaphthylene; (CAS# 208-96-8);

Anthracene; (CAS# 120-12-7);

Benz(a)anthracene; (CAS# 56-55-3);

Benzo(a)pyrene; (CAS# 50-32-8);

Benzo(b)fluoranthene; (CAS# 205-99-2);

Benzo(e)pyrene; (CAS# 192-97-2);

Benzo(ghi)perylene; (CAS# 191-24-2);

Benzo(j)fluoranthene; (CAS# 205-82-3);

Benzo(k)fluoranthene; (CAS# 207-08-9);

Chrysene; (CAS# 218-01-9);

Dibenz(a,h)anthracene; (CAS# 53-70-3);

Fluoranthene; (CAS# 206-44-0);

Indeno(1,2,3-cd)pyrene; (CAS# 193-39-5);

Naphthalene; (CAS# 91-20-3);

Phenanthrene; (CAS# 85-01-8);

Pyrene; (CAS# 129-00-0);

Benzophenone; CAS RN 119-61-9;

Bisphenol A; (BPA); CAS# 80-05-7;

Bisphenol A diglycidyl ether; (BADGE); CAS# 1675-54-3;

Bisphenol F diglycidyl ether; BFDGE; CAS# 2095-03-6;

Butylated hydroxyanisole; (BHA); CAS# 121-00-6 & 25013-16-5;

Butylated hydroxytoluene; (BHT); CAS# 128-37-0

Chlorinated paraffins;

Cyanuric acid; (Isocyanuric Acid or CYA); CAS# 108-80-5;

Dimethyl fumarate; (DMF); CAS# 624-49-7;

Dioxins;

Epichlorohydrin; (ECH); CAS# 106-89-8;

Fluorocarbons;

Fluorotelomers

Formaldehyde; CAS# 50-00-0;

- ▶ Formaldehyde in specific conditions could be formed during the resin processing (see MSDS)

Gold(Au); CAS# 7440-57-5;

Halogenated Flame Retardants

Melamine; (1,3,5-Triazine-2,4,6-triamine); CAS# 108-78-1;

Nonylphenol; CAS# 25154-52-3;

Nonylphenol ethoxylates;

Novolac glycidyl ether;

Organotin compounds;

Perfluorochemicals; (PFCs);

Perfluorooctane sulfonate; (PFOS); CAS# 1763-23-1;

Perfluorooctanoic acid; (PFOA); CAS# 335-67-1;

Plasticizers (e.g. DEHA, DINCH, BTHC, TOTM, etc.):

DEHA bis(2-ethylhexyl) adipate; CASRN: 103-23-1

DINCH 1,2-Cyclohexanedicarboxylic acid, 1,2-diisononyl ester, CASRN: 166412-78-8

BTHC butyryl tri-n-hexyl citrate; CASRN: 82469-79-2;

TOTM tris(2-ethylhexyl)benzene-1,2,4-tricarboxylate; CASRN: 3319-31-1

DINP; Diisononyl Phthalate; CASRN: 28553-12-0;

DEHP; di(2-ethylhexyl) phthalate

DOP; di-octyl phthalate; CASRN: 117-81-7;

DIDP; di-iso-decyl phthalate; CASRN: 26761-40-0;

DBP; di-butyl phthalate; or DNBP; di-n-butyl phthalate; CASRN 84-74-2;

BBP; butyl benzyl phthalate; CASRN 85-68-7;

DNOP; di-n-octyl phthalate; CASRN: 117-84-0;

Glycerides, castor-oil mono-, hydrogenated, acetates; CASRN: 736150-63-3

Polybrominated biphenyls; (PBBs);

Polybrominated diphenyl ethers; (PDBEs);

Polybrominated terphenyls; (PBTs);

Polychlorinated biphenyls; (PCBs);

Polychlorinated naphthalenes; (PCNs);

Polychlorinated terphenyls; (PCTs);

Polystyrene;

Polyvinyl chloride; (PVC); CAS# 9002-86-2;

Radioactive substances;

Radon; CAS# 10043-92-2;

Styrene monomer; CAS# 100-42-5;

Sulphur dioxide; CAS# 7446-09-5;

Tin oxide (SnO₂); (Cassiterite); CAS# 8062-08-6;

Tris-nonylphenol phosphite; (TNPP); CAS# 26523-78-4;

Vinyl chloride; CAS# 75-01-4;

Wolframite; Tungsten (W); CAS# 1332-08-7;

Ozone Depleting Substances

European Union

The ozone-depleting substances (ODS), listed in the Annexes I & II of the Regulation (EC) No 1005/2009 of 16 September 2009, are not intentionally used in the manufacture of or formulation of this product.

United States

Materials listed in the Clean Air Act Amendments of 1990 (Class I, CFC's and Class II, HCFC's, Halons and the solvents, carbon tetrachloride and 1,1,1-trichloroethane) are not intentionally used in the production of this product.

Phthalates

Phthalates are not used in the manufacture of or the formulation of this product. However, this product has not been tested for phthalates.

REACH Information

This product is manufactured by affiliates and subsidiaries of the LyondellBasell group of companies around the world.

Under the EC Regulation REACH this product is classified as a preparation. If the product has been purchased from Basell Sales & Marketing Company B.V. BSM), we confirm that all substances in this preparation have been pre-registered or, where required under REACH, registered, and that we have the intention either to proceed with their registration in accordance with the deadlines set forth in REACH, or to procure substances only from suppliers from which confirmation has been received that the suppliers are aware of their REACH requirements, that they have met their pre-registration and applicable registration obligations of their substances, and that they will supply the relevant Safety Data Sheets (SDS) with REACH registration numbers as soon as the registrations occur. In no event shall any LyondellBasell group be liable for any non-compliance deriving from false or incorrect statements of its suppliers.

We remind you, if this product is purchased from any supplier, including other companies of the LyondellBasell group, which is not established in the European Union, the importer into the European Economic Area (EEA) is responsible for compliance with the requirements of REACH.

Please contact REACH@LyondellBasell.com if you need to discuss the potential compliance with REACH before importing this product into the EEA.

REACH Substances of Very High Concern (SVHC)

This product does not contain any of the Annex XIV candidate chemicals proposed to be Substances of Very High Concern (List as of December 17, 2015) above the 0.1% threshold as stated in REACH (Article 57, Regulation No. 1907/2006) determined either through (i) non-use of the substance, (ii) mass balance calculation, or (iii) specific testing. The current list of all SVHCs can be found at ECHA website link listed below:

<http://echa.europa.eu/web/guest/candidate-list-table>

Global Chemical Control Regulations

All ingredients in this product are in compliance with the following chemical inventories:

See Section 15, of the SDS (Safety Data Sheet) for Global Chemical Inventories.

Global Toy Regulations:

CEN EN Standards refer to safety of toys and not specifically to plastic raw materials. According to the information provided by our raw material suppliers, we deem this product should comply with the requirements of CEN standards EN71-3 / EN71-9 (as amended) as applicable to plastic raw materials (pellets, powder, flakes). However, this product has not been tested according to these CEN Standards.

VOC Content

Switzerland VOC Declaration

This product contains less than 3% VOC's of the substances in the positive lists of the Switzerland Regulations "VOC-LENKUNGSABGABE."

CEN Standard prEN 13432

This product is not suitable for composting.

Energy Recovery - CEN Standard prEN 13431

The calorific gain from polyethylene in an energy recovery process is 22 MJ/Kg.

Disclaimer

The information in this document is, to our knowledge, true and accurate at the time and date of issue. However, information in this document may be updated periodically due to changes in the laws and regulations, or for other reasons, therefore we cannot guarantee that the status of this product will remain unchanged. Users are expected to regularly visit the PSInfo Website to obtain the most current information on this product. Product Stewardship Bulletins not directly received from the PSInfo system are uncontrolled documents.

Before using a product sold by a company of the LyondellBasell family of companies, users should make their own independent determination that the product is suitable for the intended use and can be used safely and legally.

SELLER MAKES NO WARRANTY; EXPRESS OR IMPLIED (INCLUDING ANY WARRANTY OF MERCHANTABILITY OR FITNESS FOR A PARTICULAR PURPOSE OR ANY WARRANTY) OTHER THAN AS SEPARATELY AGREED TO BY THE PARTIES IN A CONTRACT.

Users should review the applicable Safety Data Sheet before handling the product.

This product(s) may not be used in the manufacture of any of the following, without prior written approval by Seller for each specific product and application:

- (i) U.S. FDA Class I or II Medical Devices; Health Canada Class I, II or III Medical Devices; European Union Class I or II Medical Devices;
- (ii) film, overwrap and/or product packaging that is considered a part or component of one of the aforementioned medical devices;
- (iii) packaging in direct contact with a pharmaceutical active ingredient and/or dosage form that is intended for inhalation, injection, intravenous, nasal, ophthalmic (eye), digestive, or topical (skin) administration; tobacco related products and applications, electronic cigarettes and similar devices.

The product(s) may not be used in:

- (i) U.S. FDA Class III Medical Devices; Health Canada Class IV Medical Devices; European Class III Medical Devices;
- (ii) applications involving permanent implantation into the body;
- (iii) life-sustaining medical applications.

All references to U.S. FDA, Health Canada, and European Union regulations include another country's equivalent regulatory classification.

In addition to the above, LyondellBasell may further prohibit or restrict the use of its products in certain applications. For further information, please contact a LyondellBasell representative.

Addhere, Adflex, Adstif, Adsyl, Akoafloor, Akoalit, Alathon, Amazing Chemistry, Aquamarine, Aquathene, Avant, Catalloy, Clyrell, CRP, Crystex, Dexflex, Explore & Experiment, Flexathene, Glacido, Hifax, Histif, Hostacom, Hostalen, Ideal, Integrate, Koattro, LIPP, Lucalen, Luflexen, Lupolen, Lupolex, Luposim, Lupostress, Lupotech, Metocene, Microthene, Moplen, Nerolex, Nexprene, Petrothene, Plexar, Pristene, Proflex, Pro-Fax, Purell, Sequel, Softell, Spherilene, Spheripol, Spherizone, Starflex, Stretchene, Superflex, Topyl, Trans4m, Ultrathene, Vacido and Valtec are trademarks owned or used by the LyondellBasell family of companies.

Adsyl, Akoafloor, Akoalit, Alathon, Aquamarine, Avant, CRP, Crystex, Dexflex, Explore & Experiment, Flexathene, Hifax, Hostacom, Hostalen, Ideal, Integrate, Koattro, Lucalen, Lupolen, Microthene, Moplen, Nexprene, Petrothene, Plexar, Pristene, Pro-Fax, Purell, Sequel, Softell, Spheripol, Spherizone, Starflex, Topyl, and Ultrathene are registered in the U.S. Patent and Trademark Office.

Gerresheimer Boleslawiec S.A
ul. Boleslawa Chrobrego 15
PL - 59-700 Boleslawiec
Poland

0000145632

26358650

25.08.2015

Declaration

Remafin White 22305+

Introduction

This declaration applies exclusively to the above mentioned product when used as colouring or additive agent of a plastic food contact material and article. Our mixture is not intended to come directly in contact with food in its original form: therefore, since Clariant has no influence on subsequent processing, this declaration can not be extended to the finished material or article. Indeed, the compliance of the end material or article with the food contact regulations is the responsibility of the converter. He is committed to meet all relevant legal requirements and to test the migration limits according the conditions of use (temperature, time, simulants) of the article in its finished form (e.g. volume, geometry, thickness). These conditions are not part of our knowledge and therefore are not under Clariant's control.

Framework Regulation (EC) No. 1935/2004 and GMP Regulation No 2023/2006

Framework Regulation (EC) No. 1935/2004 sets out the general rules that must be met by all classes of food contact materials without giving any specific rule of how to prove the safety of food contact articles: plastic materials are covered by specific measures in relation to component types used in the formulation of our mixtures:

- polymers and additives are regulated by Regulation (EU) No 10/2011 and its amendments.
- colourants (including dyes, organic and inorganic pigments) must not migrate and must also comply with the purity requirements laid down in the national laws of Member States. General requirements for colourants are listed in the EU Resolution of the Council of Europe, AP (89) 1 though this is not legally binding.
- catalysts, solvents and polymer production aids (not yet listed at EU level) shall be assessed with general rules of the Framework Regulation by the substance manufacturer and/or shall comply with the national legislations provisions.

The product is not expected to cause any contravention to the Framework Regulation since the subsequent stages of manufacture, processing and distribution of the end article are in line with the Good Manufacturing Practices (GMP) applicable to food contact materials and article's supply chain, as listed in Regulation (EC) No 2023/2006. In addition, we would declare that our own production process, as a part of this supply chain will conform to the provisions of GMP.

Hereafter the status of the different component types is given according to their applicable legislation and based on the declarations received by Clariant from starting materials suppliers:

Commission Regulation (EU) No 10/2011 and its amendments

All the carriers and the intentionally added additives comply with the requirements of Regulation (EU) No 10/2011 and its amendments published before the release date of this certificate. We would like to remind you that the assessment of overall migration limit and other release restrictions such as those found in Annex II (e.g. the release of aromatic amines in a detectable quantity) is the responsibility of the producer of the finished article (converter). Information regarding components subjected to further specific limitations and concerning the presence of dual-use additives is given hereunder.

Restrictions and Limitations

- Barium sulphate: SML (T) = 1 mg/Kg expressed as Barium.
- Zinc sulfide: SML(T) = 25 mg/kg (as zinc) see also note (38)
- Triethanolamine, SML = 0.05 mg/kg, SML expressed as the sum of triethanolamine and of hydrochloride adduct expressed as triethanolamine.
- Zinc salts (including double salts and acid salts) of authorised acids, phenols or alcohols: SML = 25 mg/kg (expressed as Zn)
- 1,1,1-Trimethylolpropane: SML = 6mg/kg

Please note, that the following dual-use-additives are contained:

FCM number / name of the additive / content of the additive (given in range)

106	Stearic acid & derivatives	1 - 2,5 %
610	Titanium dioxide	40 - 60 %

SML	Specific Migration Limit	SML(T)	Specific Migration Limit expressed as Total
DL/LR/NG	Detection Limit	FP/PF/BG	Finished Product or Article

European Resolution AP (89) 1

All the colourants used meet the requirements established in European Resolution AP(89) 1 in regard to the maximum permissible levels of heavy metals, primary aromatic amines, sulphonated aromatic amines and polychlorinated biphenyls.

Belgium: Arrêté Royal from 11.05.1992 of the Moniteur Belge 24.07.1992

All the colourants used meet the purity requirements listed in the Arrêté Royal from 11.05.1992 of the Moniteur Belge 24.07.1992 and its amendments.

France: Jorf

All the colorants fulfil the applicable requirements and restrictions for food contact applications.

Germany: BfR Recommendation IX

There are no objections to the use of the colourants in this product according to the Recommendation IX of the BfR (Federal Institute for Risk Assessment).

Italy: Decreto Ministeriale

All the colourants used, meet the purity requirements listed in the Decreto Ministeriale of 21.03.1973 and its amendments.

The Netherlands: Warenwet

All the colourants used meet the purity requirements listed in the Dutch regulation Warenwet and its amendments.

Spain: Real Decreto 847/2011 (subsecretaria para Sanidad)

All the colourants used meet the purity requirements listed in Annex II of Real Decreto 847/2011 (subsecretaria para Sanidad) and its amendments.

Turkey: Food Codex Regulation

All the components used meet the requirements of Turkish Food Codex Regulation on materials and articles which are intended to come into contact with foodstuffs issued in December 29th 2011 and its amendments.

We would also like to inform you of the status of our product in regard to the Directive 94/62/EC, CONEG (Regulation status and the content of diarylide pigments):

Directive 94/62/EC and CONEG

Based on the knowledge of the raw materials as well as of the manufacturing process, we are able to confirm that the product does not contain intentionally added heavy metals. The product meets the requirements of the Directive 94/62/EC and the CONEG regulation which limits the content of heavy metals up to 100 ppm (Cd, Pb, Hg, Cr(VI)). National regulations such as D.L.22 del 5/02/97 (IT), Ley de envases y residuos de envases 11/97 (ES) are also satisfied.

Diarylide Pigments

The product does not contain any intentionally added diarylide pigment in its chemical composition.

Clariant Polska Spółka z o.o.

This information corresponds to the present state of our knowledge and is intended as a general description of our products and their possible applications. Clariant makes no warranties, express or implied, as to the information's accuracy, adequacy, sufficiency or freedom from defect and assumes no liability in connection with any use of this information. Any user of this product is responsible for determining the suitability of Clariant's products for its particular application. Nothing included in this information waives any of Clariant's General Terms and Conditions of Sale, which control unless it agrees otherwise in writing. Any existing intellectual/industrial property rights must be observed. Due to possible changes in our products and applicable national and international regulations and laws, the status of our products could change. Material Safety Data Sheets providing safety precautions, that should be observed when handling or storing Clariant products, are available upon request and are provided in compliance with applicable law. You should obtain and review the applicable Material Safety Data Sheet information before handling any of these products. For additional information, please contact Clariant.

** For sales to customers located within the United States and Canada the following applies in addition:*

NO EXPRESS OR IMPLIED WARRANTY IS MADE OF THE MERCHANTABILITY, SUITABILITY, FITNESS FOR A PARTICULAR PURPOSE OR OTHERWISE OF ANY PRODUCT OR SERVICE.

9/2010

Katarzyna Malinowska
Gerresheimer Boleslawiec S.A.

PL -
Poland

22573417

17.04.2013

Declaration

REMAFIN-WHITE PE 22305+

Introduction

This document is intended provide information on the current status of the above-referenced materials under certain regulatory programs. Please review this document carefully and contact your Clariant representative if you have any questions.

All statements refer exclusively to the named product in its current formulation: they are based on the present state of our knowledge and experience and concern the product in its original form and packaging as supplied from our factory.

Since the masterbatch and compound manufacturer has no influence on subsequent processing, the processor himself is responsible for ensuring that the finished article is suitable for the intended use, and is also responsible for ascertaining the compliance of the end article with the national and international regulations and laws concerning its application field. Due to the broad range of possible applications we make no warranty that the actual use of the product in the finished article is comprised by the information below.

Hereafter the status of the different component types is given according to their applicable legislation and based on the declarations received by Clariant from starting materials suppliers:

USA Food and Drug Administration

In the USA substances used as a component of articles intended to come into contact with food are regulated by Food and Drug Administration FDA 21 CFR Title 21. Specific limitations and conditions of use, as set forth in these regulations, are specified below. Please note the maximum use rate specified below must be met to ensure regulatory compliance.

The components entering into the formulation of the above-referenced product are approved under one or more of the specific FDA paragraphs or have other clearances listed below:

1. Colorants listed in 21 CFR 178.3297 "Colorants for Polymers."
2. Components that are exempt from regulation under 21 CFR 170.39, "Threshold of Regulation for Substances Used in Food Contact Articles."
3. Polymers and/or additives listed in the appropriate parts of 21 CFR (174, 175, 176, 177, 178, 181, 182, 184 and 186).
4. Substances that, based upon legal opinion, supplier certification, and/or extraction results from food-simulating solvents, are not food additives and are acceptable for food contact applications in full compliance with the Federal Food, Drug and Cosmetic Act and all applicable food additive regulations.
5. Substances that are GRAS (Generally Recognized as Safe) for direct addition to food or for use in contact with food.

- 6. Substances that are "Prior Sanctioned" for use in this application.
- 7. Substances that are the subject of applicable Food Contact Substance Notifications.

The above statement is valid only if the dosage ratio listed below is not exceeded in the application polymer:

Application polymer	Max. let-down ratio (w/w)
HDPE	No limitation.
The above-mentioned declaration is only valid if the finished article is not used for packing or containing food during cooking (conditions of use C through G described in title 21 CFR, §176.170(c)).	
LLDPE	No limitation.
The above-mentioned declaration is only valid if the finished article is not used for packing or containing food during cooking (conditions of use C through G described in title 21 CFR, §176.170(c)).	
LDPE	No limitation.
The above-mentioned declaration is only valid if the finished article is not used for packing or containing food during cooking (conditions of use C through G described in title 21 CFR, §176.170(c)).	
PP	No limitation.
The above-mentioned declaration is only valid if the finished article is not used for packing or containing food during cooking (conditions of use C through G described in title 21 CFR, §176.170(c)).	

We would also like to inform you of the status of our product in regard to the Directive 94/62/EC, CONEG Regulation status and the content of diarylide pigments:

Directive 94/62/EC and CONEG

Based on the knowledge of the raw materials as well as of the manufacturing process, we are able to confirm that the product does not contain intentionally added heavy metals. The product meets the requirements of the Directive 94/62/EC and the CONEG regulation which limits the content of heavy metals up to 100 ppm (Cd, Pb, Hg, Cr(VI)). National regulations such as D.L.22 del 5/02/97 (IT), Ley de envases y residuos de envases 11/97 (ES) are also satisfied.

Diarylide Pigments

The product does not contain any intentionally added diarylide pigment in its chemical composition.

Clariant Masterbatches Norden AB

Country Product Stewardship

This declaration was produced automatically, and therefore does not have an original signature.

For sales to customers located within United States and Canada

This information corresponds to the present state of our knowledge and is intended for the exclusive use of the named recipient. Any user of this product is responsible for determining the suitability of Clariant's products for its particular application.

NO WARRANTY IS MADE OF THE MERCHANTABILITY OR FITNESS FOR USE OF ANY PRODUCT, AND NOTHING INCLUDED IN THIS INFORMATION WAIVES ANY OF CLARIANT'S GENERAL TERMS AND CONDITIONS OF SALE, WHICH CONTROL UNLESS IT AGREES OTHERWISE IN WRITING.

Due to possible changes in our products and applicable national and international regulations and laws, the status of our products could change. Material Safety Data Sheets providing safety precautions, that should be observed when handling or storing Clariant products, are available upon request. You should obtain and review the applicable Material Safety Data Sheet information before handling any of these products. For additional information, please contact Clariant.

For sales to customers located outside the United States and Canada

This information corresponds to the present state of our knowledge and is intended as a general description of our products and their possible applications. Clariant makes no warranties, express or implied, as to the information's accuracy, adequacy, sufficiency or freedom from defect and assumes no liability in connection with any use of this information. Any user of this product is responsible for determining the suitability of Clariant's products for its particular application. Nothing included in this information waives any of Clariant's General Terms and Conditions of Sale, which control unless it agrees otherwise in writing. Any existing intellectual/industrial property rights must be observed. Due to possible changes in our products and applicable national and international regulations and laws, the status of our products could change. Material Safety Data Sheets providing safety precautions, that should be observed when handling or storing Clariant products, are available upon request and are provided in compliance with applicable law. You should obtain and review the applicable Material Safety Data Sheet information before handling any of these products. For additional information, please contact Clariant.

Katarzyna Malinowska
Gerresheimer Boleslawiec S.A.

PL -
Poland

22733386

27.05.2013

Declaration

REMAFIN-WHITE PE 22305+

Introduction

All statements refer exclusively to the named product in its current formulation: they are based on the present state of our knowledge and experience and concern the product in its original form and packaging as supplied from our factory.

Since the masterbatch and compound manufacturer has no influence on subsequent processing, the processor himself is responsible for ensuring that the finished article is suitable for the intended use, and is also responsible for ascertaining the compliance of the end article with the national and international regulations and laws concerning its application field.

Additional information

- Based on the current formulation of the above mentioned product, the following substances have not been intentionally added during its production:

Gluten
Lactose
Allergens
Latex
Phthalates, Melamine, Bisphenol A

These substances were not used as starting materials during the mixing phase of our product but, on the basis of our current knowledge, we cannot give you any warranty they are not constitutionally contained (or are present as impurities at trace level) in raw materials. Please note that, in any case our Company does not carry out any specific analysis in order to detect the presence of above mentioned substances.

In addition be informed that, in case here above was not clearly mentioned, you can find the following information into the Safety Data Sheet you already got by us:

- the ingredients that may be classified as dangerous for health and environment;
- information on restriction on use that we are aware of and that could be relevant for plastic applications.

Clariant Masterbatches Norden AB

Country Product Stewardship

This declaration was produced automatically, and therefore does not have an original signature

For sales to customers located outside the United States and Canada

This information corresponds to the present state of our knowledge and is intended as a general description of our products and their possible applications. Clariant makes no warranties, express or implied, as to the information's accuracy, adequacy, sufficiency or freedom from defect and assumes no liability in connection with any use of this information. Any user of this product is responsible for determining the suitability of Clariant's products for its particular application. Nothing included in this information waives any of Clariant's General Terms and Conditions of Sale, which control unless it agrees otherwise in writing. Any existing intellectual/industrial property rights must be observed. Due to possible changes in our products and applicable national and international regulations and laws, the status of our products could change. Material Safety Data Sheets providing safety precautions, that should be observed when handling or storing Clariant products, are available upon request and are provided in compliance with applicable law. You should obtain and review the applicable Material Safety Data Sheet information before handling any of these products. For additional information, please contact Clariant.

For sales to customers located within United States and Canada

This information corresponds to the present state of our knowledge and is intended for the exclusive use of the named recipient. Any user of this product is responsible for determining the suitability of Clariant's products for its particular application.

NO WARRANTY IS MADE OF THE MERCHANTABILITY OR FITNESS FOR USE OF ANY PRODUCT, AND NOTHING INCLUDED IN THIS INFORMATION WAIVES ANY OF CLARIANT'S GENERAL TERMS AND CONDITIONS OF SALE, WHICH CONTROL UNLESS IT AGREES OTHERWISE IN WRITING.

Due to possible changes in our products and applicable national and international regulations and laws, the status of our products could change. Material Safety Data Sheets providing safety precautions, that should be observed when handling or storing Clariant products, are available upon request. You should obtain and review the applicable Material Safety Data Sheet information before handling any of these products. For additional information, please contact Clariant.



TEST REPORT

Client

Gerresheimer Vaerloese
Walgerholm 2-8
DK-3500 Vaerloese
Denmark

Gregersensvej
DK-2630 Taastrup
Telephone +45 72 20 20 00
Telefax +45 72 20 20 19

Report No 603427/2

1347624
10 June 2014
HEAN

info@teknologisk.dk
www.teknologisk.dk

Specifications

Closure

Type: Duma Handy Cap 4015
Number: 004015-2000
Raw material: LD 653 (PE-LD)
Colour: White, PEZ121818X
Cavity: 1 - 32 (Mould A-D)

Container

Type: Duma Special 50 ml
Number: 043050-0000
Raw material: GF 4760 (PE-HD)
Colour: White, PE 22305+
Cavity: 10-15 (Mould 3)

Test period: 27 May – 10 June 2014

Water Vapour Permeation

10 specimens of containers and closures have been tested according to USP 37 <671>. For containers used for drugs being dispensed on prescription, the containers so tested are *tight containers* if not more than one of the 10 test containers exceeds 100 mg per day per litre in moisture permeability, and none exceeds 200 mg per day per litre.

The work has been carried out according to the General Terms and Conditions regarding commissioned work accepted by the Danish Technological Institute.

Results

mg water vapour per day per litre container-volume:

No 1	No 2	No 3	No 4	No 5	No 6	No 7	No 8	No 9	No 10
6.7	5.5	7.4	8.7	9.0	6.1	6.6	6.1	8.1	8.1

Average: 7.2 mg/d/l

Conclusion

The tested containers comply with the requirement of USP 37 <671> test for tight containers used for drugs being dispensed on prescription.

Centre: Packaging and Logistics

Helle Antvorskov, Senior Consultant
Phone: +45 72 20 31 69
e-mail: hean@dti.dk

Test responsible

Helle Allermann, Senior Consultant
Phone: +45 72 20 31 63
e-mail: heal@dti.dk

Co-reader



Test Report

Client

Gerresheimer Vaerloese
Walgerholm 2-8
DK-3500 Vaerloese
Denmark

Report No 517199/26

22 March 2013
1347624
HEAN

Specifications

Container

Type: Duma Special 50 ml
Number: 043050-0000
Raw material: GF4760 (HDPE)
Colour: White, PE 22305+ 4.5%
Cavity no: 13 (Mould 3)

Date of receipt: 22 March 2013
Test period: 22 March 2013

Light Transmission

Samples from the container have been tested according to USP 35 <671>.
Requirement: The light transmission must not exceed 10 % in the range from 290 to 450 nm. Enclosure 1 shows the spectra from 290 to 450 nm of the samples from the container.

Results

maximum % light transmission:

Sample No 1	Sample No 2
7.6	8.3

Conclusion

The tested container complies with the requirement of USP 35 <671>.

Centre: Packaging and Logistics

Søren R. Østergaard
Head of packaging section



Helle Antvorskov
Senior consultant

Gerresheimer Vaerloese

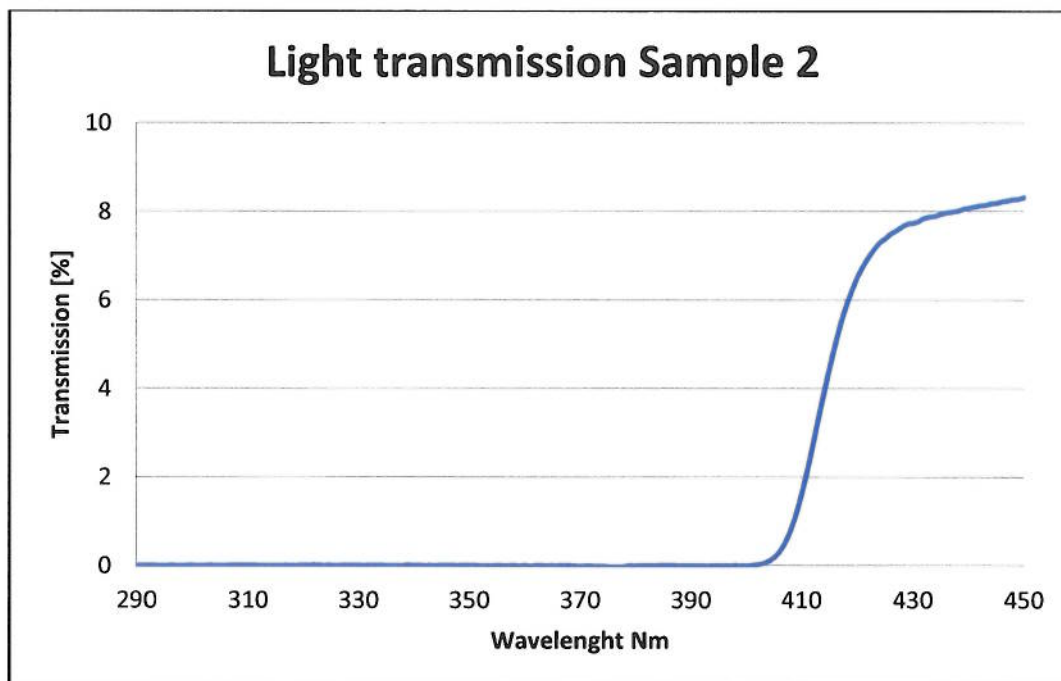
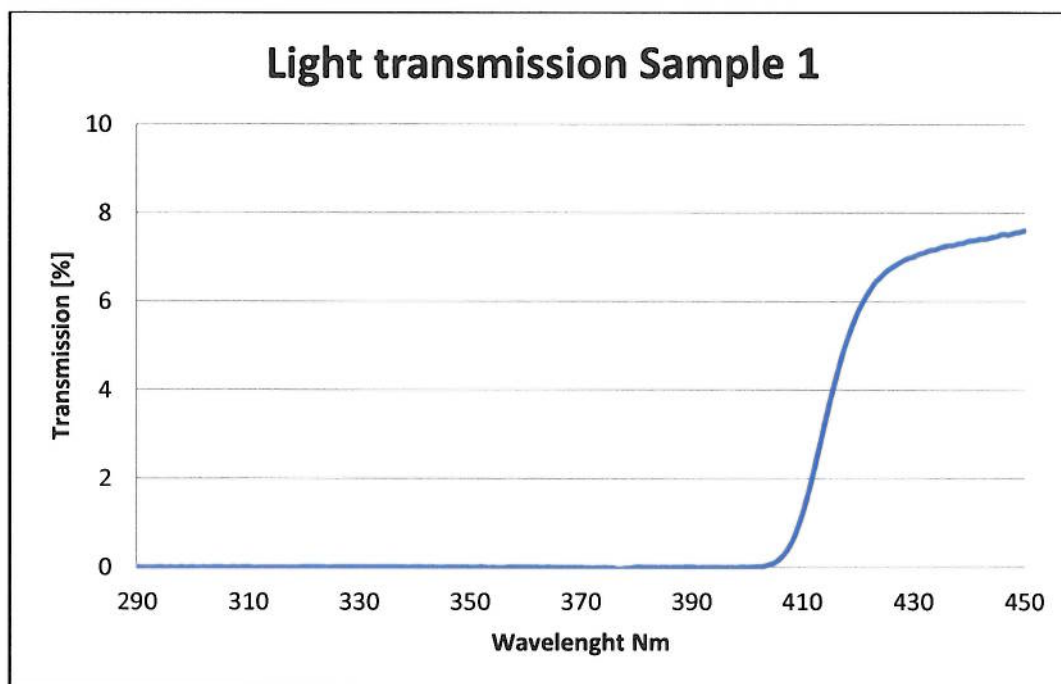
Type: Duma Special 50 ml
Number: 043050-0000

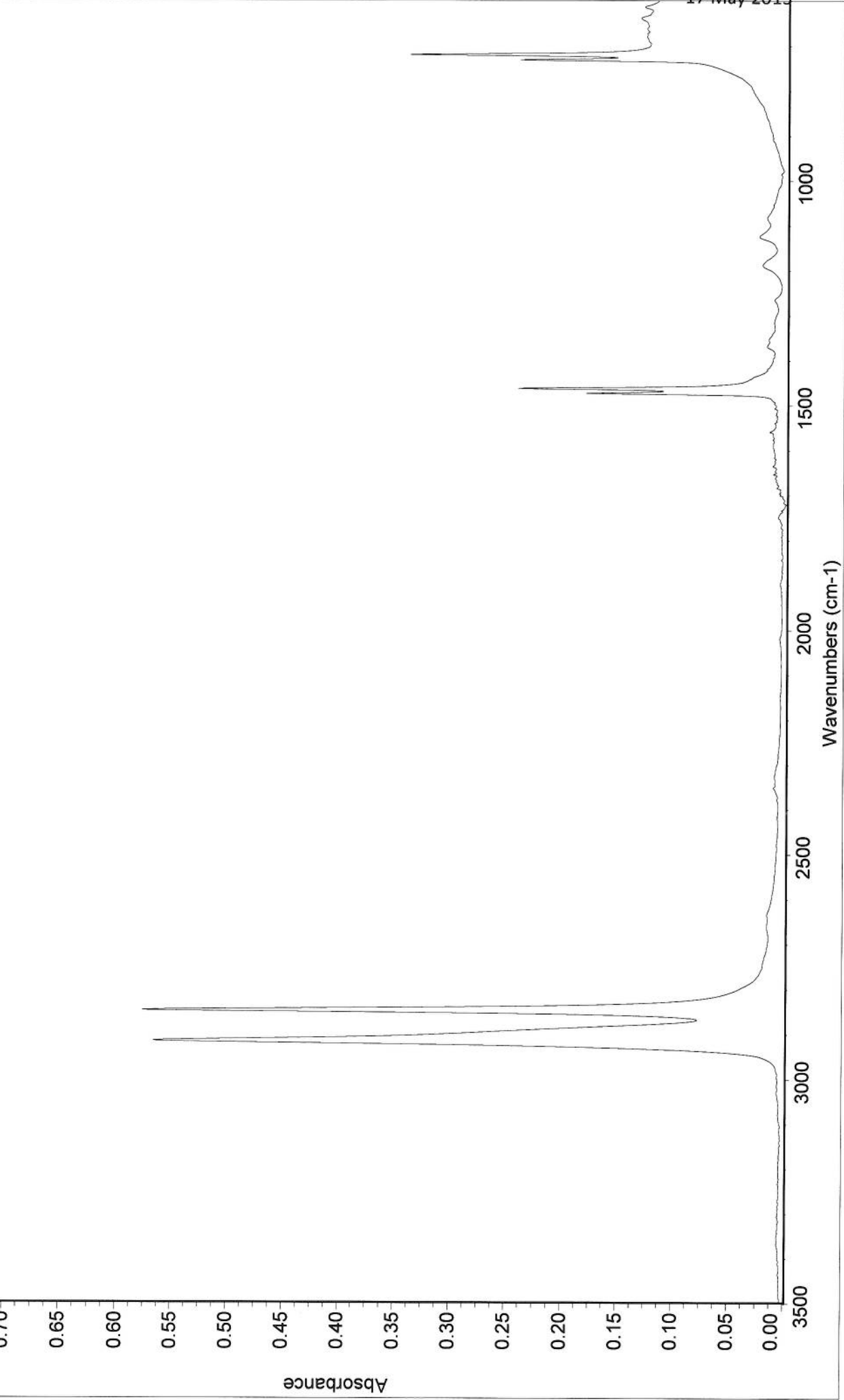

DTI
1: Type:Duma Twist-Off 100ml. Number:045100-3000. Raw material:GF 4760(HDPE). Colour:White,PE 22305+. Produced:15.04.2013
Thu May 16 09:06:44 2013 (GMT+02:00)
P:\FTIR\iS50 2013\Maj 2013\05034.SPA





Gerresheimer
Att.: Rene Palmelund
Walgerholm 2-8
DK-3500 Værløse
Denmark

Gregersensvej
DK-2630 Taastrup
Tel. +45 72 20 20 00
Fax +45 72 20 20 19

info@teknologisk.dk
www.teknologisk.dk

Test report no. 36901-2

Test required: Duma Twist-Off 15 ml.
Migration tests and heavy metals according to USP 34 <661>

Sampling by: Client

Sampling received: 11 June 2012

Test period: 11 – 27 June 2012

Remarks: The results of the analysis and method summary are given on the next pages. The results relates only to the analysed subsamples. The results were forwarded by e-mail.

The test is carried out on the basis of Danish Technological Institute's Conditions for Regulating Liability". This report shall not be reproduced except in full without the written approval of Laboratory for Chemistry and Microbiology, Danish Technological Institute.

Laboratory for Chemistry and Microbiology, Taastrup

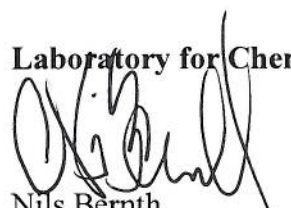
Nils Bernth
Lab. Manager, M.Sc.

Sesse Rasmussen
Technician

Introduction

According to agreement, migration tests were performed in accordance with USP 34 <661>.

Test Conditions

- Surface/volume ratio = 3 cm²/cm³
- Extraction with H₂O for 24 hours at 70°C
- Determination of non-volatile residue by evaporation at 105°C
- Determination of heavy metals e.g. antimony, arsenic, bismuth, cadmium, copper, lead, mercury, molybdenum, silver and tin by ICP-MS in extract.
- Determination of buffering capacity by titration
- Determination of non-volatile residue after extraction with ethanol for 24 hours at 70°C and with hexane for 24 hours at 50°C

Duplicate determinations were performed.

Results for: Duma Twist-Off 15 ml

Non-volatile Residue, Buffer capacity and Heavy Metal after H₂O-Extraction

Lab. no.	Non-volatile Residue mg/50 ml Extract		Residue on Ignition of Non-volatile Residue		Heavy Metals Content in Extract determined by ICP-MS	
	Measured	Requirement	Measured	Requirement	Measured	Requirement
36901-2	1.3	< 12	*	< 5	< 0.1 ppm	< 1 ppm

Comments

*: If "Non-volatile Residue" is below 5 mg this test is not required.

Heavy metals are determined as the sum of the concentrations of Ag, As, Bi, Cd, Cu, Hg, Mo, Pb, Sb and Sn, if the measured concentration is below DL, then DL is used in the sum. The requirement is below 1 ppm (mg/kg) in the extract.

The measurements are based on independent double determinations.

Buffer capacity after H₂O-Extraction

Lab. no.	Buffer Capacity ml 0.010 N NaOH/20 ml Extract	
	Measured	Requirement
36901-2	< 1	< 10

Non-volatile Residue after Ethanol and Hexane Extraction

Lab. no.	Extraction media	Non-volatile Residue mg/50 ml Extract	
		Measured	Requirement
36901-2	Ethanol	0	< 75
36901-2	Hexane	5.0	< 100

Comments

Duplicate determinations were performed.

Conclusion

The results fulfil the requirements of USP 34 <661>.

Quality Control

Classification of defects

Effects of defects	Defect class	Individual permitted defect		Total permitted defect		Consequence
		Containers / Caps	Containers / Caps	Containers / Caps	Containers / Caps	
Critical defects are defects as defined in ISO 2859 which endanger human life and health or contravene legal requirements or lead to destruction or alterations of the filling material or seriously impair the reliability of production tools, filling and packaging equipment	1	0	0	0	0	Packaging material not usable
Major defects are defects as defined in ISO 2859 which lead to inefficient function and so to deficiency of the packaging material/pack or result in complaints from user or lead to reduced efficiency in production or impair the reliability of production, tools, filling and packaging equipment	2A	0.25	0.1	0.65	0.4	Usability of packaging material markedly impaired
	2B	1.0	0.4	2.5	1.0	Usability of packaging material moderately impaired
Minor defects are defects as defined in ISO 2859 which lead to a reduction of general quality	3	4.0	2.5	6.5	6.5	Usability of packaging material slightly impaired

AQL values for IBM containers - Vaerloese

Defects	Defect class
Incorrect use of raw materials, wrong identification, mix-up, unspecified holes and non removable and/or coarse, loose internal contamination (e.g. oil, insects etc.)	1
Dimensions and wall thickness outside specifications	2A
Defects on sealing points, not fully cast, deformation, inhomogeneous distribution of material, uneven surface	2A
Inhomogeneous colour, removable internal contamination, external contamination such as oil, dust etc., foreign bodies enclosed in material	2A
Flashes, impurities such as black spots, burned material, black stripes in splitline and bottom, notches and clefts	2B
Black spots which are not visible from a distance of ½ m	3

Quality control for IBM containers - Vaerloese

Activity	Control
Incoming control of raw materials	Identification of goods received and control of certificates.
Set-up new mould or change of raw materials or control specification	Line clearance including control of correct use of raw materials. 3 samples of each cavity produced at the same time are visually controlled as well as checked for critical dimensions with plug-and ring gauges by production and QC prior to production start.
Production	<p>QC operator performs a visual control of the products in accordance with ISO 2859-1. The samples are taken every hour (one sample per cavity produced at the same time). A sample of each cavity is checked for critical dimensions with plug-and ring gauges every second hour.</p> <p>New approval by production and QC is required after machine stops lasting more than 1 hour.</p> <p>In case of unplanned machine stops where products can be defected the products are 100% controlled or scrapped.</p> <p>If defects are detected, products are quarantine stored or 100% controlled.</p>
Quality control	<p>QC reviews all the production documentation and point out products that need additional control. This also includes follow-up on products which are quarantine stored by production.</p> <p>QC controls the dimensions of the samples from two of the in-process controls with plug-and ring gauges.</p> <p>QC controls the pallets for mix-up and incorrect labeling, releases the products and issue certificates with the results of the controls.</p>